



## Safety and Shut-off Block SAF/DSV

### 1. DESCRIPTION

#### 1.1. GENERAL

The HYDAC safety and shut-off block is used to shut off and discharge hydraulic accumulators or consumers.

It complies with the relevant safety standards in accordance with DIN EN 982 and the German industrial safety regulations BetrSichV.

The Hydac pressure relief valve DB12 is used on the SAF series. This is a direct-operated pressure relief valve in poppet valve construction with excellent opening and closing properties. This version of DB12 conforms to the requirements of the Pressure Equipment Directive 97/23/EC with CE marking and is supplied with a declaration of conformity and an operating manual.

**Please read the operating manual!  
No. 5.169.B**

#### 1.1.1 Key to the circuit diagram

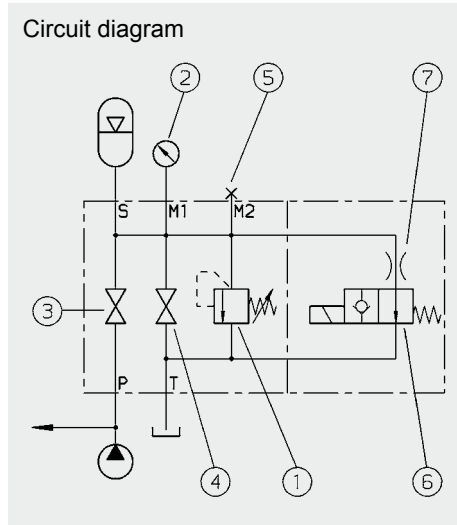

① Safety valve to prevent excess pressure to PED 97/23/EC

② Pressure gauge

③ Shut-off valve

④ Pressure release valve

⑤ Connection for test gauge

These devices are combined in a compact, space-saving HYDAC safety and shut-off block. The following devices are also available:

⑥ Solenoid-operated pressure release valve

⑦ Throttle

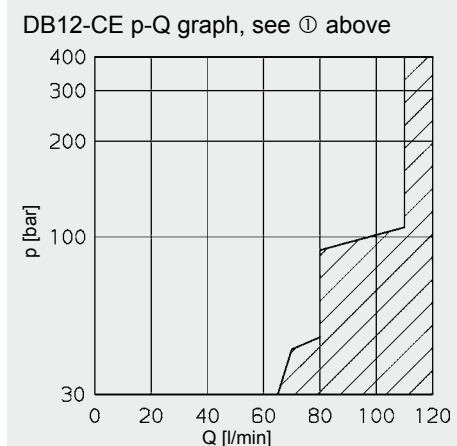

This valve cannot be set to values in the shaded area

#### 1.1.2 Product benefits

The compact combination of components considerably simplifies the connection of an accumulator or consumer to the hydraulic system and provides the following benefits:

- Minimum of space, maintenance and installation required. As all the individual units are combined in one block, considerably fewer pipe fittings are necessary for installation
- Considerable reduction in installation time.
- All types of connections for various accumulator designs and makes are available - imperial and metric connections as well as manifold mounted and weld nipple.
- Additional valves such as pilot-operated check valves, flow control valves and combined flow control and check valves can be fitted to the system connection P.

## 1.2. CONSTRUCTION

The SAF safety and shut-off block consists of a valve block, an integral HYDAC pressure relief valve, a main shut-off valve and a manually operated pressure release valve, and the necessary gauge connections are provided in addition to the tank connection.

In addition, an optional solenoid-operated 2-way directional valve allows automatic discharge of the accumulator or consumer and therefore of the hydraulic system in an emergency or for shut-down.

## 1.3. PORTS

The safety and shut-off block has the following ports:

- S – Accumulator port
- P – Inline port (pump)
- T – Tank port
- M1 – Test gauge port  
G 1/2 - ISO 228  
(G 1/4 for SAF10)
- M2 – Gauge connection  
G 1/4 - ISO 228

## 1.4. SPECIFICATIONS

### 1.4.1 Operating fluids

Mineral oil to DIN 51524  
Part 1 and Part 2  
(other fluids on request)

### Viscosity range

Min. 10 mm<sup>2</sup>/s  
Max. 380 mm<sup>2</sup>/s

### Filtration

Max. permitted contamination level of the operating fluid to SAE AS 4059 Class 11.

We therefore recommend a filter with a minimum retention rate of  $\beta_{20} \geq 100$ .

The fitting of filters and regular replacement of filter elements guarantees correct operation, reduces wear and tear and extends the service life.

### 1.4.2 Permitted operating temperature

-10 °C ... +80 °C

(ambient temperature on E version limited to -10 °C ... +60 °C)

### 1.4.3 Max. operating pressure

400 bar

### 1.4.4 Model with solenoid-operated pressure relief

#### Type of operation

Solenoid-operated by means of pressure-tight, oil-immersed, single-stroke solenoids in accordance with VDE 0580. Actuating solenoid with male connector to DIN 43650, standard for general industrial applications, available for 24 V DC and 230 V AC.

#### Type of voltage

DC solenoid

When connected to AC voltage, the necessary DC voltage is produced by means of a bridge rectifier connector.

#### VOLTAGE TOLERANCE

± 15% of the nominal voltage

#### Nominal current

depending on the nominal voltage

24 V DC 0.80 A

230 V AC 0.11 A

#### Power consumption

$p_{20} = 18 \text{ W}$

#### DUTY

100% = continuous operation

#### Switching time

Depending on symbol, pressure across the individual ports and flow rate:

WSM06020Y:

On: 50 ms, Off: 35 ms

WSM06020Z:

On: 35 ms, Off: 50 ms.

## 1.5 STANDARD MODELS

### 1.5.1 Model with manually operated pressure release valve

The basic model Safety and Shut-off Block has a manually operated pressure release valve, code "M", and a direct-operated pressure relief valve.

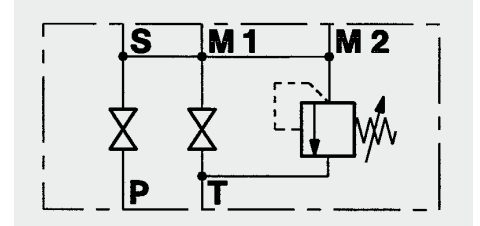

Sizes: SAF10M

SAF20M

SAF32M

### 1.5.2 Model with solenoid-operated pressure relief

The "E" model safety and shut-off block incorporates a solenoid-operated 2-way directional valve (open when de-energised) (standard) for automatic pressure relief of the accumulator and the hydraulic system.

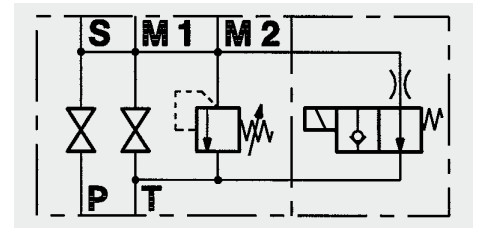

Sizes: SAF10E

SAF20E

SAF32E

## 1.6. $\Delta p$ -Q GRAPHS FOR SAF

with DB12 pressure relief valve

### 1.6.1 Flow from the pump to the accumulator

SAF10M/E

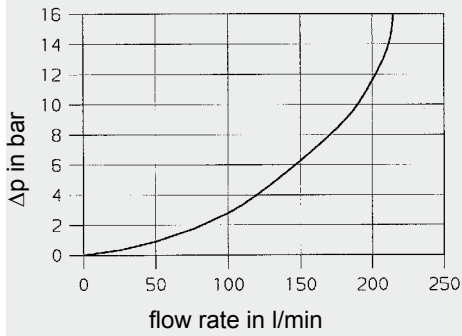

### 1.6.2 Flow from the accumulator via the solenoid-operated pressure release valve to the tank

SAF10E

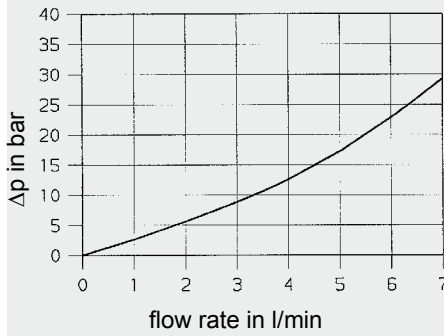

### 1.6.3 Flow from the accumulator via the pressure release valve to the tank

SAF10M/E

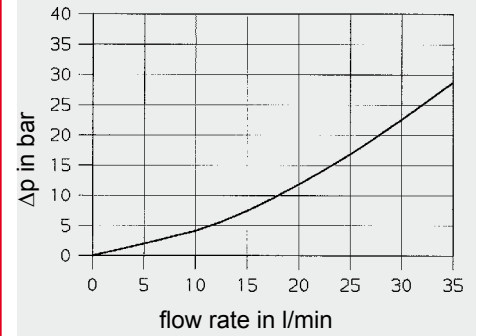

SAF20M/E

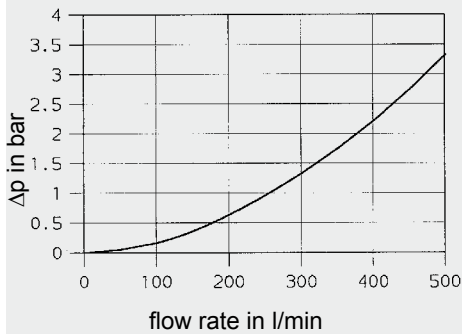

SAF20E

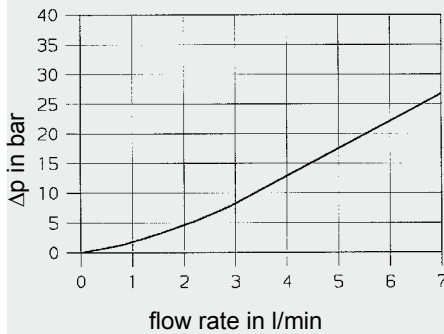

SAF20M/E

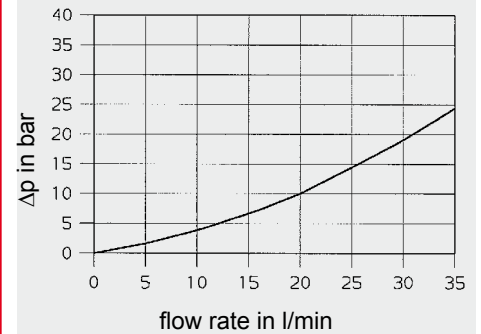

SAF32M/E

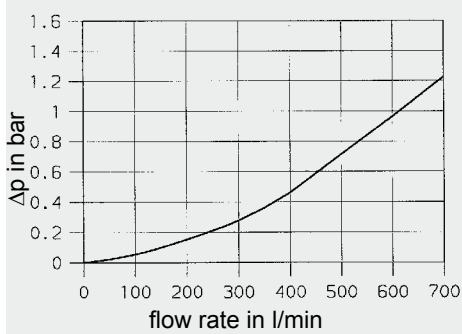

SAF32E

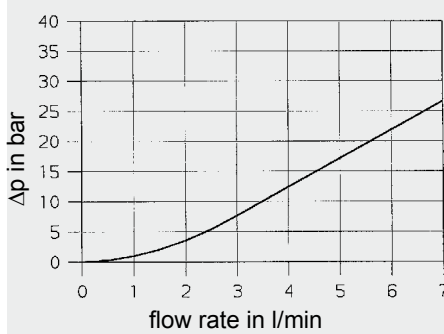

SAF32M/E

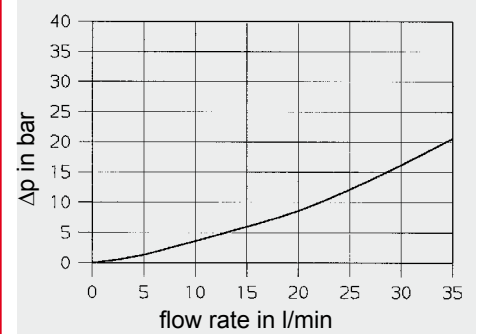

① measured at:  
 $v = 32 \text{ mm}^2/\text{s}$   
 $t_{\text{oil}} = 40 \text{ }^\circ\text{C}$   
 Operating pressure = 400 bar

## 2. MODEL CODE FOR SAF

(also order example)

SAF 20 E 1 2 Y 1 T 210 A - S 13 - LPI

### Safety and shut-off block

Series SAF

### Size of main shut-off valve

- 10 = DN10
- 20 = DN20
- 32 = DN32
- 32-3 = DN32 with 3 pressure relief valves size 12
- 50 = DN50

### Type of operation

- M = Manual discharge
- E = Solenoid-operated and manual discharge

### Block material

- 1 = Carbon steel
- Other materials<sup>1)</sup>

### Seal material (elastomer)

- 2 = NBR (Perbunan)
- 5 = EPDM
- 6 = FPM (Viton®)
- 7 = Other

### For solenoid-operated discharge with manual override

- Y = Open when de-energised (2/2 directional valve WSM06020Y)
- Z = Closed when de-energised (2/2 directional valve WSM06020Z, only up to 350 bar)

### Type of voltage - directional poppet valve

- 1 = 24 VDC
- 2 = 115 VAC
- 3 = 230 VAC
- 6 = 120 VAC
- 7 = Other

### Pressure relief valve

- T... = Pressure-set and lead-sealed by TÜV
- N... = Pressure-set without TÜV inspection<sup>1)</sup>

### Pressure setting

e.g. 210 bar

### Threaded connections to

- A = ISO 228 (BSP)
- B = DIN 13, to ISO 965/1 (metric)<sup>1)</sup>
- C = ANSI B1.1 (UNF, O-ring seal to SAE)<sup>1)</sup>

### Adapter

to accumulator (see point 7)  
e.g. S13 = ISO 228 - G 2A

### Additional equipment (see point 5.4)

- L = lockable main shut-off valve (for use with padlock)
- LPI = model L with additional position monitoring (inductive proximity switch)
- LPM = model L with additional position monitoring (mechanical limit switch with roller lever)

### Accessories

(When ordering, please give full details: see point 7, Accessories)

<sup>1)</sup> On request

### 3. DIMENSIONS

#### 3.1. SAF10 SAFETY AND SHUT-OFF BLOCK SIZE 10

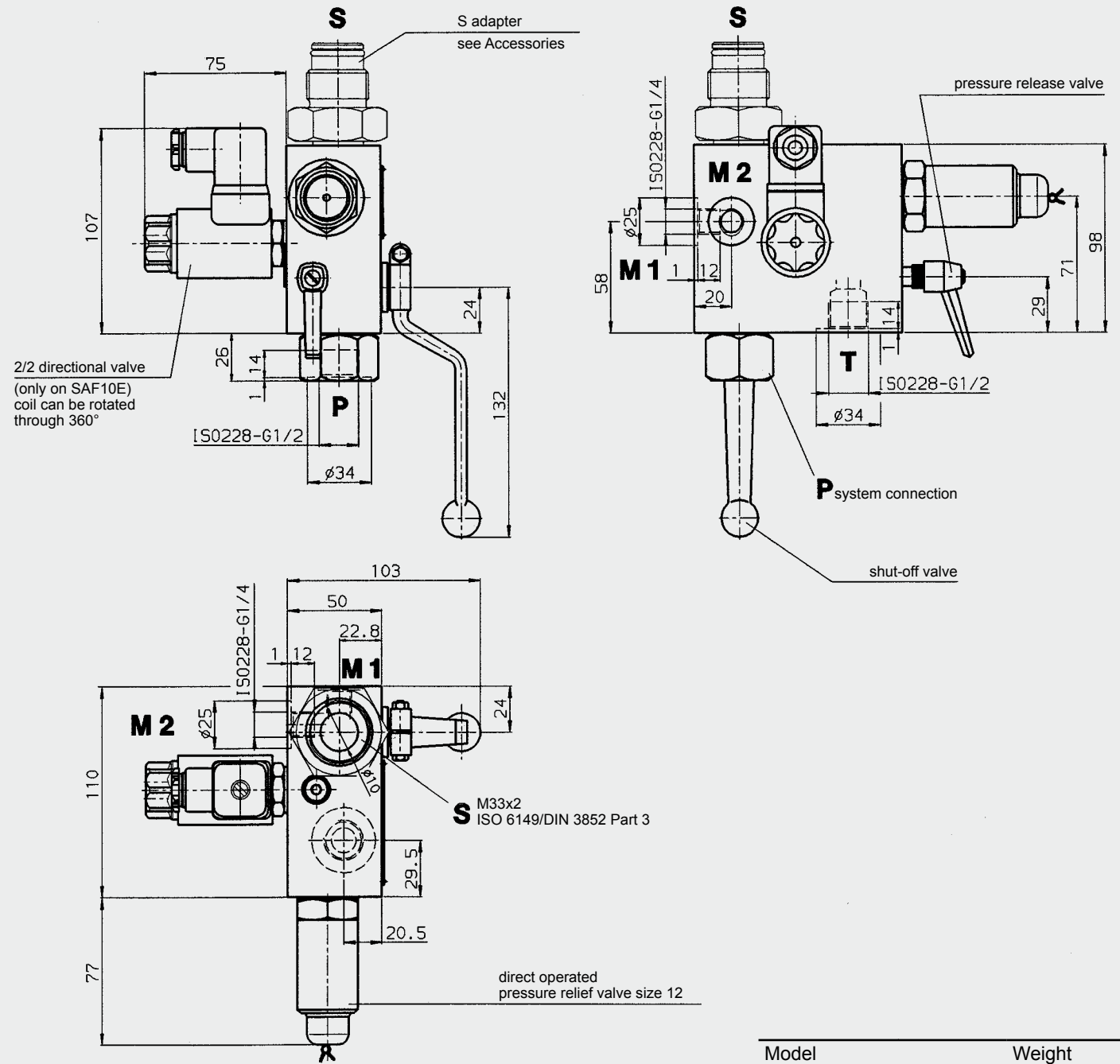

Model	Weight
SAF10M...	4.2 kg
SAF10E...	4.6 kg

#### SAF10 Standard models

Model	Part no.	Model	Part no.
SAF10M12T400A	2121582	SAF10E12Y1T400A	2125858
SAF10M12T350A	2122208	SAF10E12Y1T350A	2122210
SAF10M12T330A	2121236	SAF10E12Y1T330A	2122211
SAF10M12T315A	2121121	SAF10E12Y1T315A	2122212
SAF10M12T300A	2121354	SAF10E12Y1T300A	2122213
SAF10M12T250A	2121353	SAF10E12Y1T250A	2122214
SAF10M12T210A	2121346	SAF10E12Y1T210A	2121662
SAF10M12T200A	2121351	SAF10E12Y1T200A	2122215
SAF10M12T150A	2121345	SAF10E12Y1T150A	2122216
SAF10M12T100A	2121344	SAF10E12Y1T100A	2122041
SAF10M12T070A	2121350	SAF10E12Y1T070A	2122217
SAF10M12T050A	2122207	SAF10E12Y1T050A	2122218
SAF10M12T035A	2121349	SAF10E12Y1T035A	2122219

### 3.2. SAF20 SAFETY AND SHUT-OFF BLOCK SIZE 20

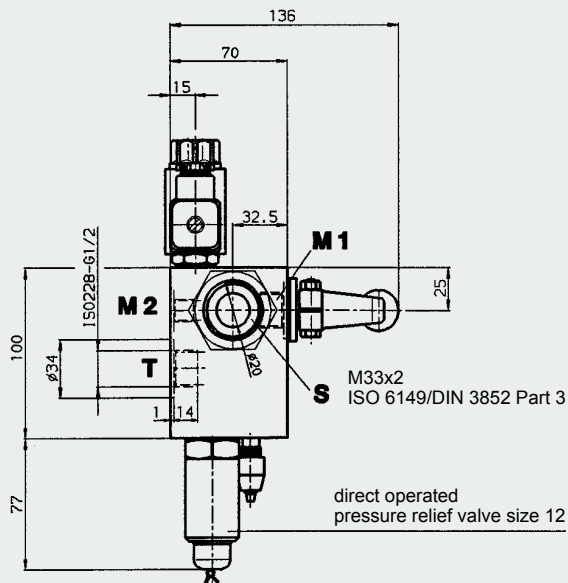
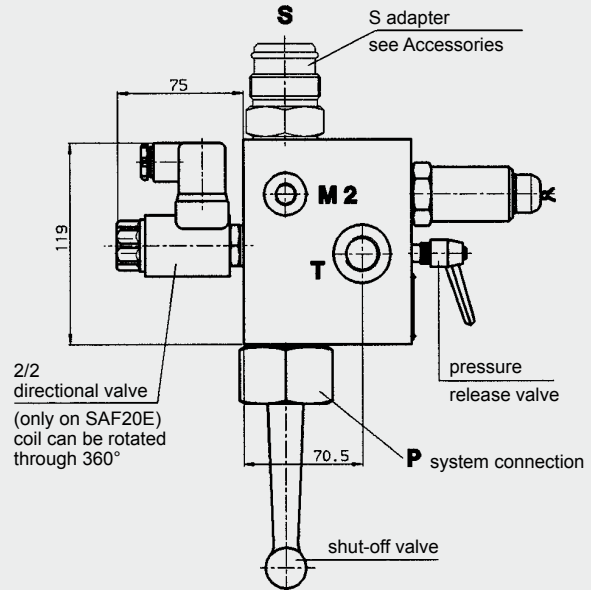
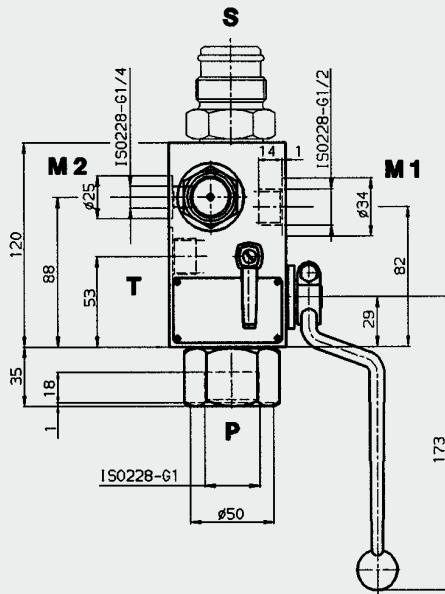

Model	Weight
SAF20M...	6.8 kg
SAF20E...	7.2 kg

#### SAF20 Standard models

Model	Part no.	Model	Part no.
SAF20M12T400A	2120317	SAF20E12Y1T400A	2121022
SAF20M12T350A	2120434	SAF20E12Y1T350A	2121979
SAF20M12T330A	2120323	SAF20E12Y1T330A	2120394
SAF20M12T315A	2120324	SAF20E12Y1T315A	2120833
SAF20M12T300A	2120332	SAF20E12Y1T300A	2120836
SAF20M12T250A	2120432	SAF20E12Y1T250A	2120851
SAF20M12T210A	2120319	SAF20E12Y1T210A	2120320
SAF20M12T200A	2120325	SAF20E12Y1T200A	2120835
SAF20M12T150A	2120330	SAF20E12Y1T150A	2120832
SAF20M12T100A	2120401	SAF20E12Y1T100A	2120369
SAF20M12T070A	2120326	SAF20E12Y1T070A	2120849
SAF20M12T050A	2122172	SAF20E12Y1T050A	2121000
SAF20M12T035A	2120281	SAF20E12Y1T035A	2122220

### 3.3. SAF32 SAFETY AND SHUT-OFF BLOCK SIZE 32

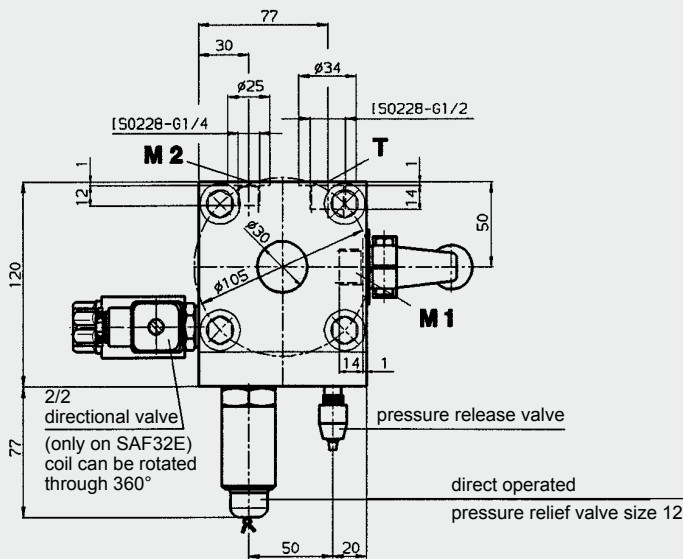
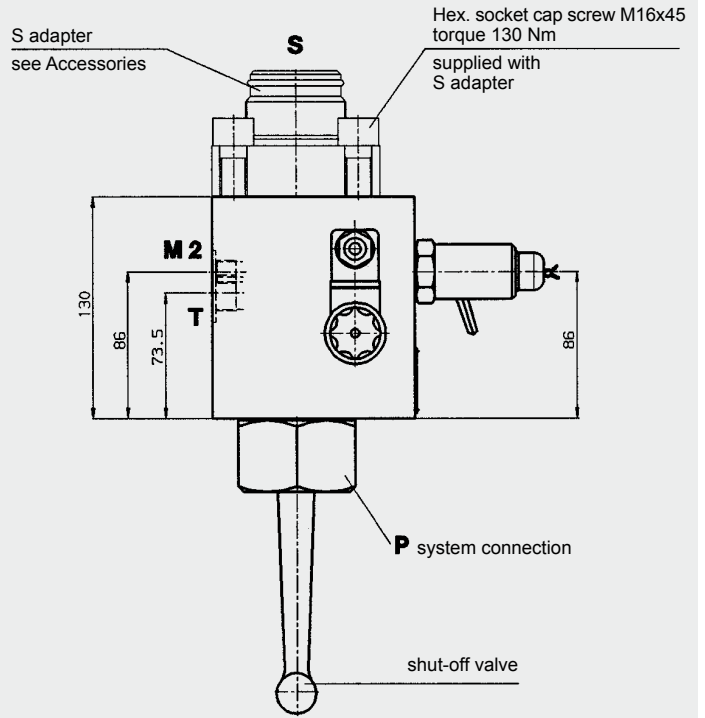
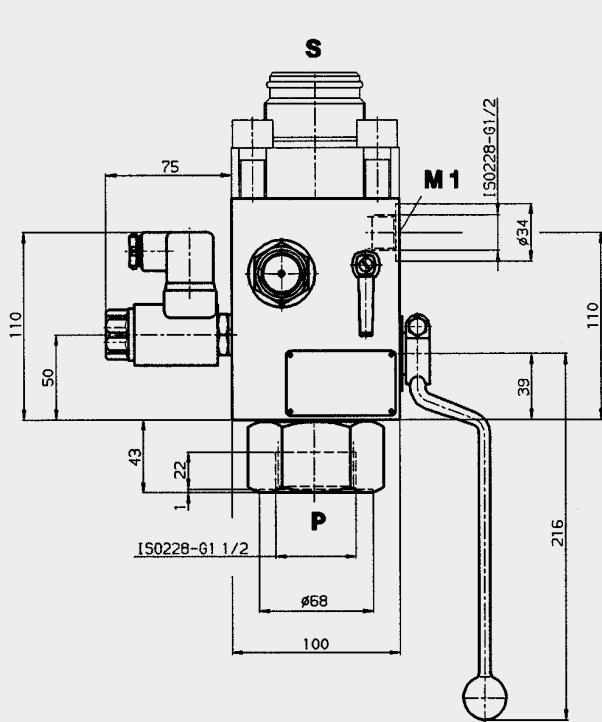

Model	Weight
SAF32M...	12.0 kg
SAF32E...	12.4 kg

#### SAF32 Standard models

Model	Part no.	Model	Part no.
SAF32M12T400A	2125856	SAF32E12Y1T400A	2123123
SAF32M12T350A	2122230	SAF32E12Y1T350A	2122221
SAF32M12T330A	2122231	SAF32E12Y1T330A	2120371
SAF32M12T315A	2121136	SAF32E12Y1T315A	2122222
SAF32M12T300A	2120837	SAF32E12Y1T300A	2120834
SAF32M12T250A	2122233	SAF32E12Y1T250A	2122223
SAF32M12T210A	2120321	SAF32E12Y1T210A	2120318
SAF32M12T200A	2121135	SAF32E12Y1T200A	2122224
SAF32M12T150A	2121134	SAF32E12Y1T150A	2122225
SAF32M12T100A	2121129	SAF32E12Y1T100A	2122226
SAF32M12T070A	2122234	SAF32E12Y1T070A	2122227
SAF32M12T050A	2121137	SAF32E12Y1T050A	2122228
SAF32M12T035A	2121125	SAF32E12Y1T035A	2122229

## 4. SPARE PARTS

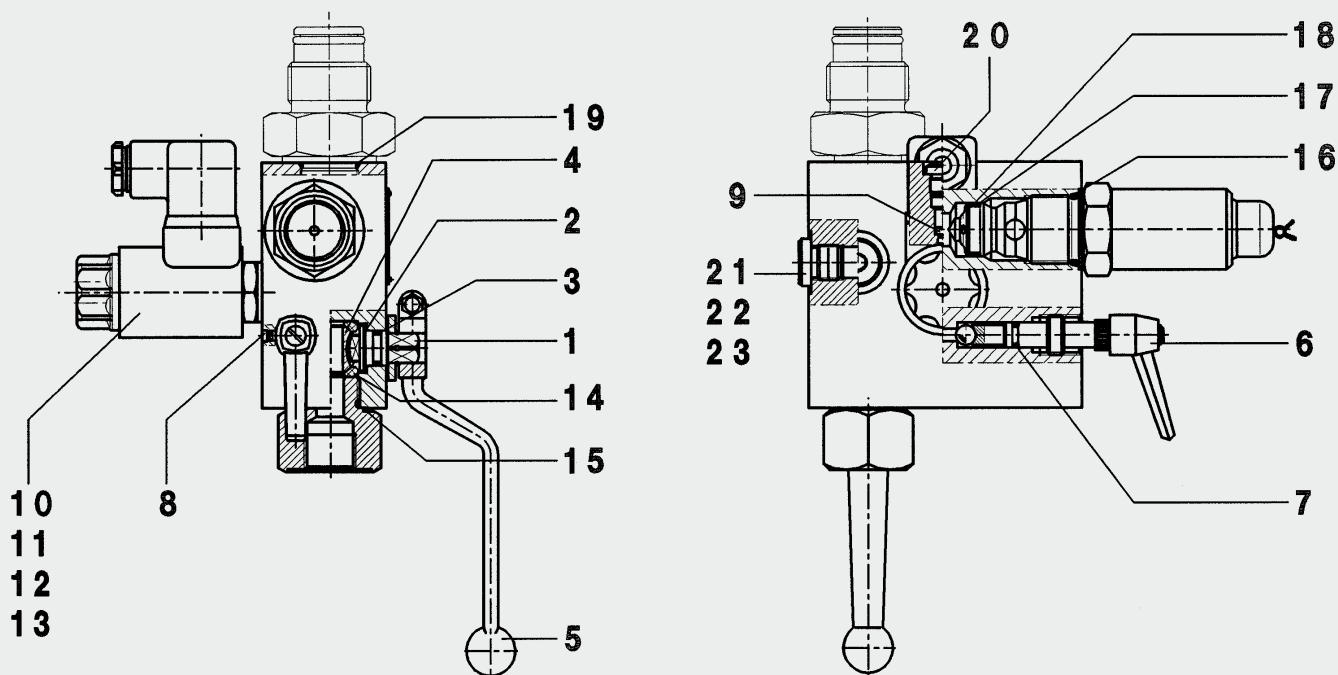

SAF Block		SAF10M SAF10E	SAF20M SAF20E	SAF32M SAF32E
Description	Item	Dimensions		
<b>Repair kit</b>		Part no.	Part no.	Part no.
consisting of:		2122238 (NBR)	2122242 (NBR)	2122246 (NBR)
		2122240 (FPM)	2122244 (FPM)	2122248 (FPM)
Spindle	1			
Disc	2			
O-ring	3	10x2	15x2.5	20x3
Ball	4			
Switching handle	5			
Spindle	6			
O-ring	7	6x2		
Set screw	8	M4x6	M4x10	
Slip-in orifice	9	Ø1.5 mm (Q <sub>max</sub> - 25.5 l/min)		
O-ring	11	17x2		
Back-up ring	12	11.7x15x1		
O-ring	13	11x2		
Sealing cup	14			
O-ring	15	21x2	34x2.5	56.7x2.8
O-ring	16	23.47x2.62		
Back-up ring	17	18.3x21.5x1		
O-ring	18	18x2		
O-ring	19	29.7x2.8	29.7x2.8	37.2x3
Blanking plug	20	G 1/8	G 1/8	G 1/8
	21	G 1/4	G 1/4	G 1/4
	22	-	G 3/8	G 3/8
	23	-	G 1/2	G 1/2
<b>2/2 directional valve assembly</b> (only for E-version)	10	Part no. 3156869 (WSM06020Y open when de-energised)		
<b>Blanking plug assembly</b> (converts "E" version to "M" version)		3156873 (WSM06020Z closed when de-energised)		
		277645		
<b>Seal kit</b>		Part no.	Part no.	Part no.
consists of: Items 3, 7, 8, 11, 12, 13, 14, 15, 16, 17, 18, 19, 20, 21, 22, 23		2121699 (NBR)	2121703 (NBR)	2121707 (NBR)
		2121701 (FPM)	2121705 (FPM)	2121709 (FPM)
<b>Spindle repair kit</b>		Part no.		
consists of: Items 6, 7, 8		2115648 (NBR)		
		2115649 (FPM)		

## 5. SPECIAL MODELS

### 5.1. TYPE SAF32-3M(E)

with 3 direct operated pressure relief valves size 12  
(max. operating pressure 400 bar)

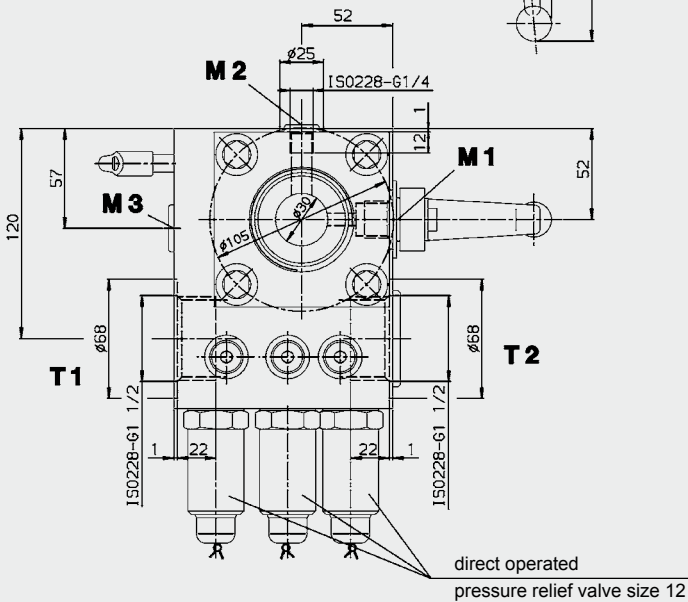
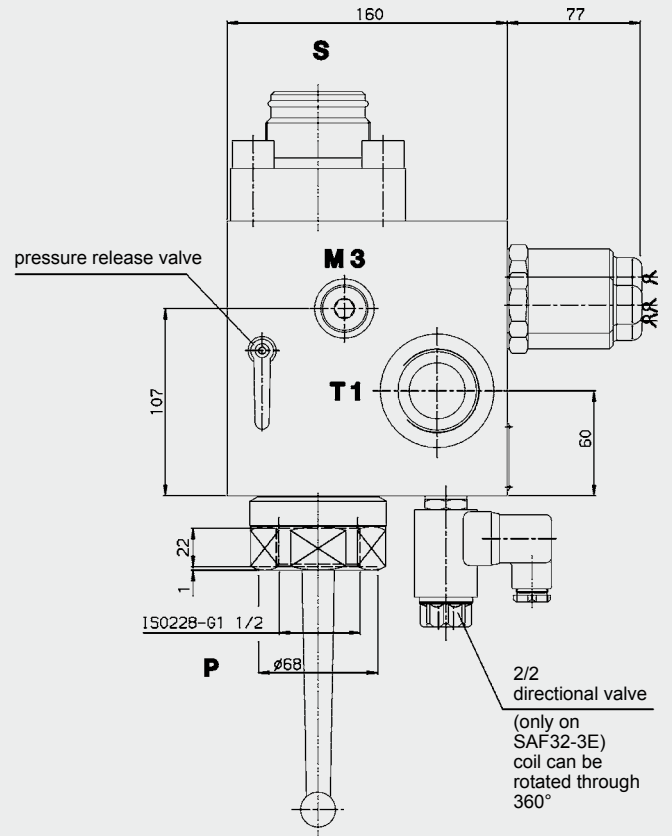
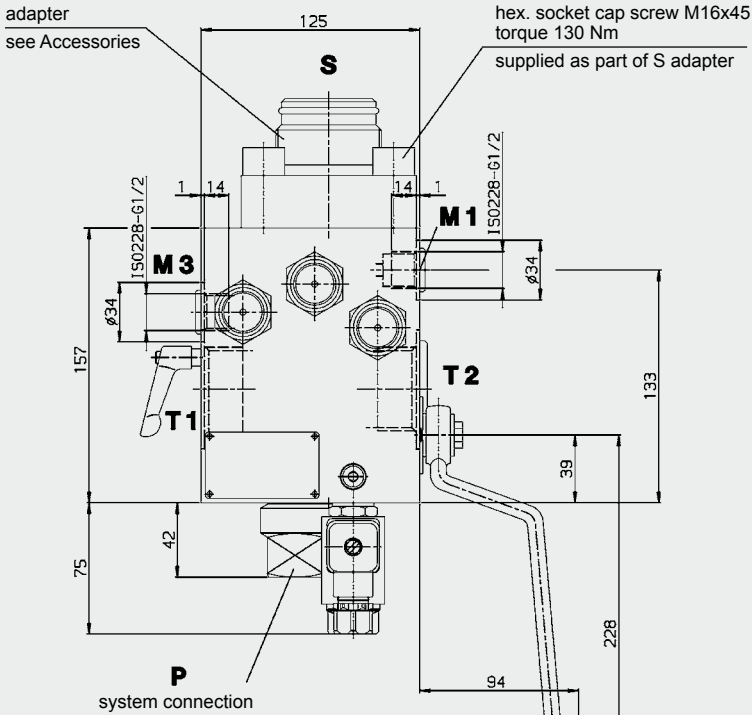

SAF32-3M

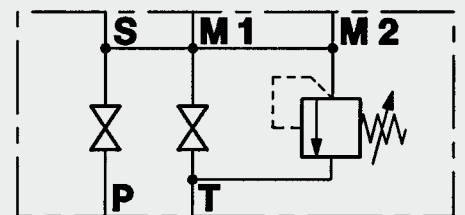

SAF32-3E

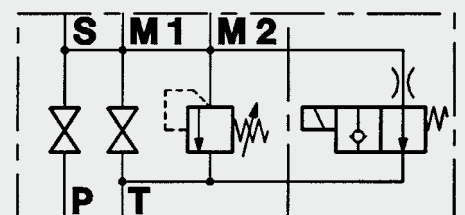

Model	Weight
SAF32-3M...	24 kg
SAF32-3E...	25 kg

## 5.2. TYPE SAF50M(E)

for large flows  
with 3 direct operated pressure relief valves size 12  
(max. operating pressure 400 bar)

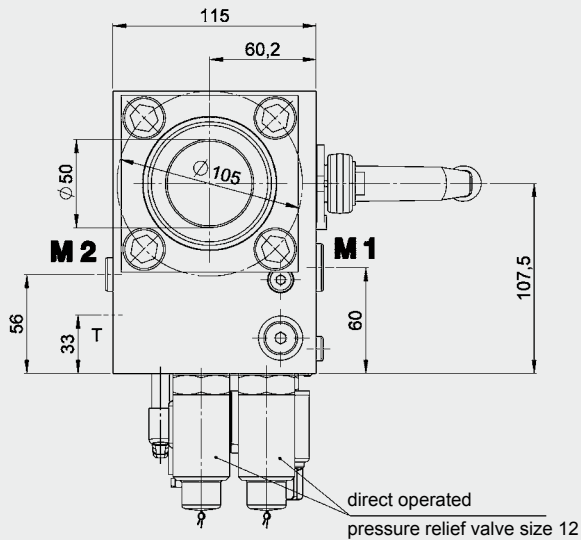
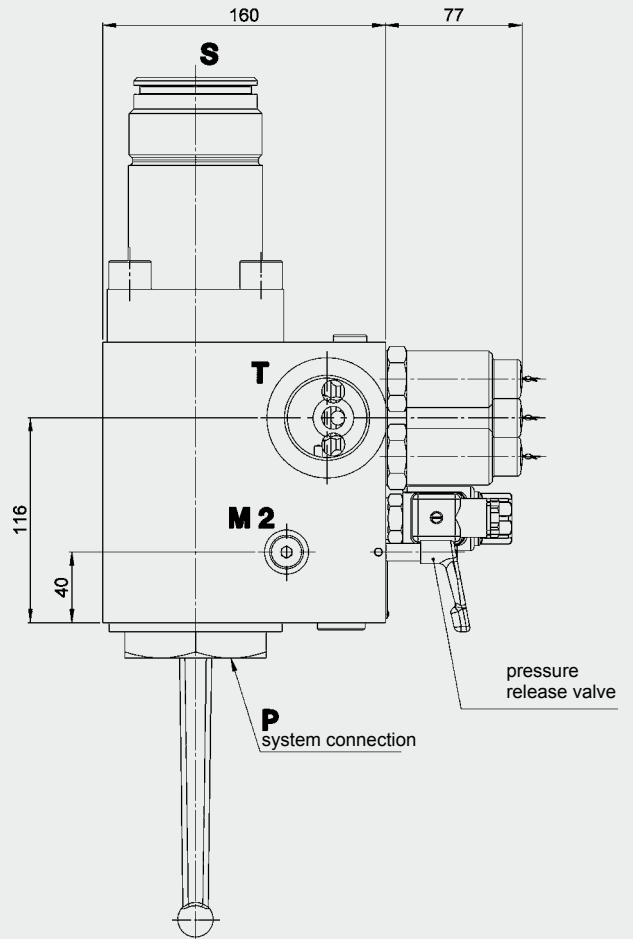
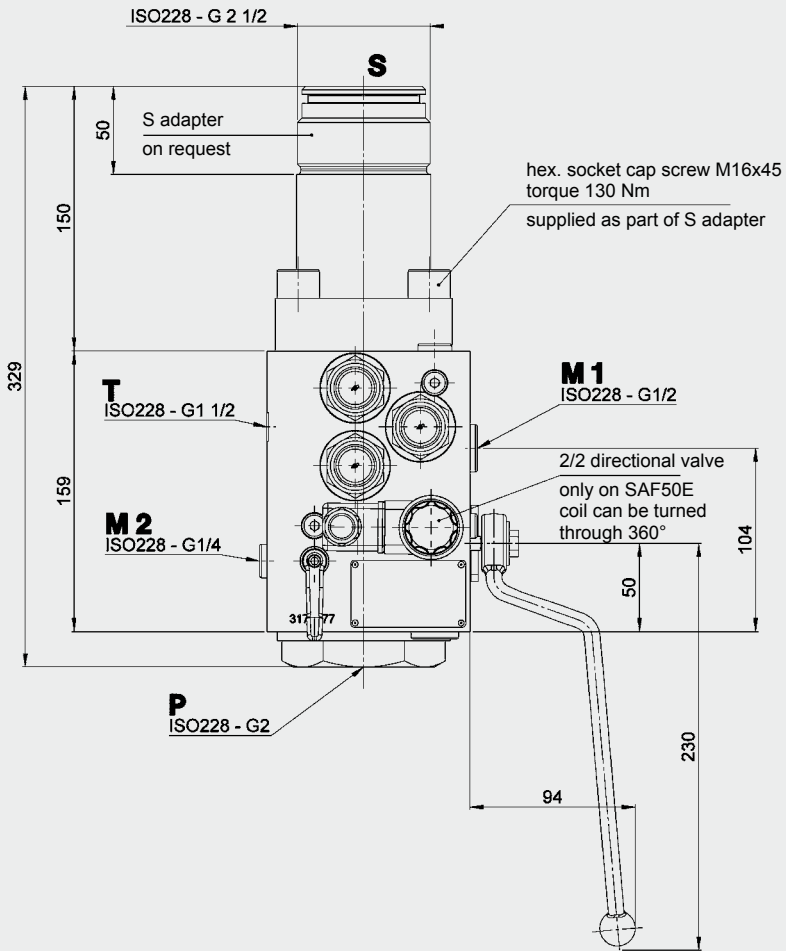

SAF50M

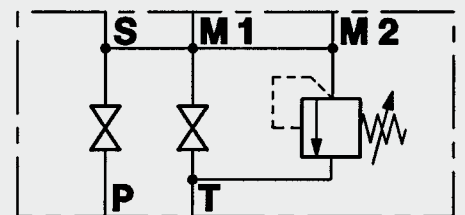

SAF50E

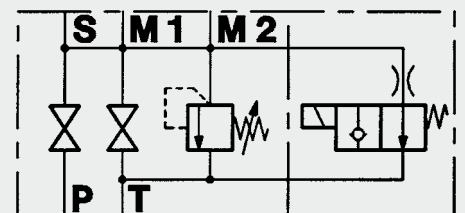

Model	Weight
SAF50M...	25 kg
SAF50E...	26 kg



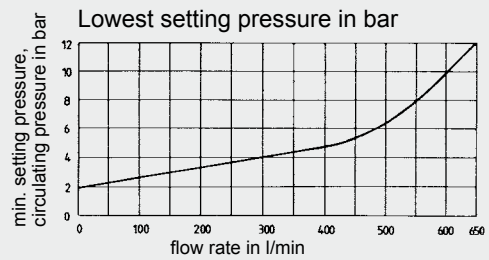
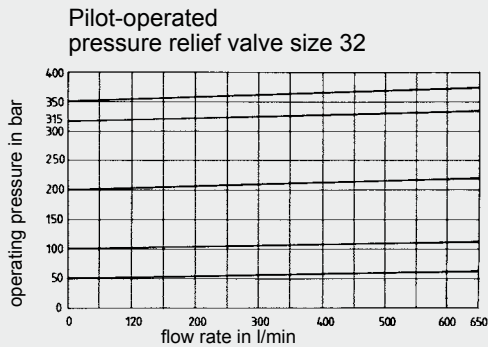
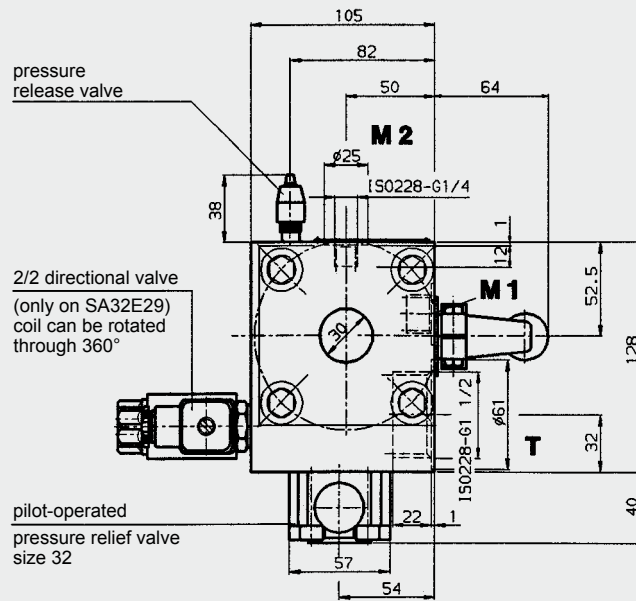

#### SA32E29TVY

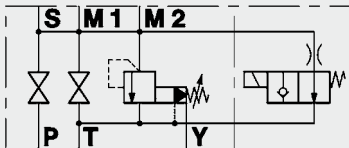

#### SA32E29TV

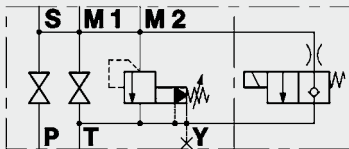

#### SA32M29TVY

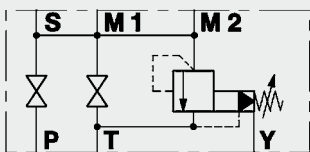

#### SA32M29TV

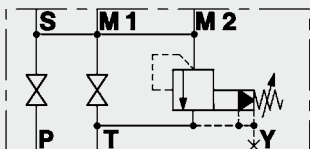

The safety and shut-off block SA32M(E)29 is equipped with a pilot-operated pressure relief valve size 32 for high flow rates up to 600 l/min.

The E version of the safety and shut-off block has a solenoid-operated 2-way directional valve for automatic pressure release of the accumulator and the hydraulic system in an emergency or for shut-down.

For unpressurised tank lines, valve type "TV" must be used (with internal oil return to tank).

For pressurised tank lines, valve type "TVY" is recommended (with external oil return to tank).

Two different models of the 2-way directional valve are available:

- WSM06020Y (open when de-energised)
- WSM06020Z (closed when de-energised)

Model	Weight
SA32M29...	22.5 kg
SA32E29...	23.5 kg

## 5.4. SAFETY AND SHUT-OFF BLOCK WITH ADDITIONAL EQUIPMENT

Safety and shut-off blocks are available with a device to enable the shut-off valve to be locked in either the open or the closed position, by fitting a padlock.

It is also possible to fit inductive proximity switches or roller-actuated limit switches to control the open and closed position of the shut-off valve.

### 5.4.1 Additional device LPI

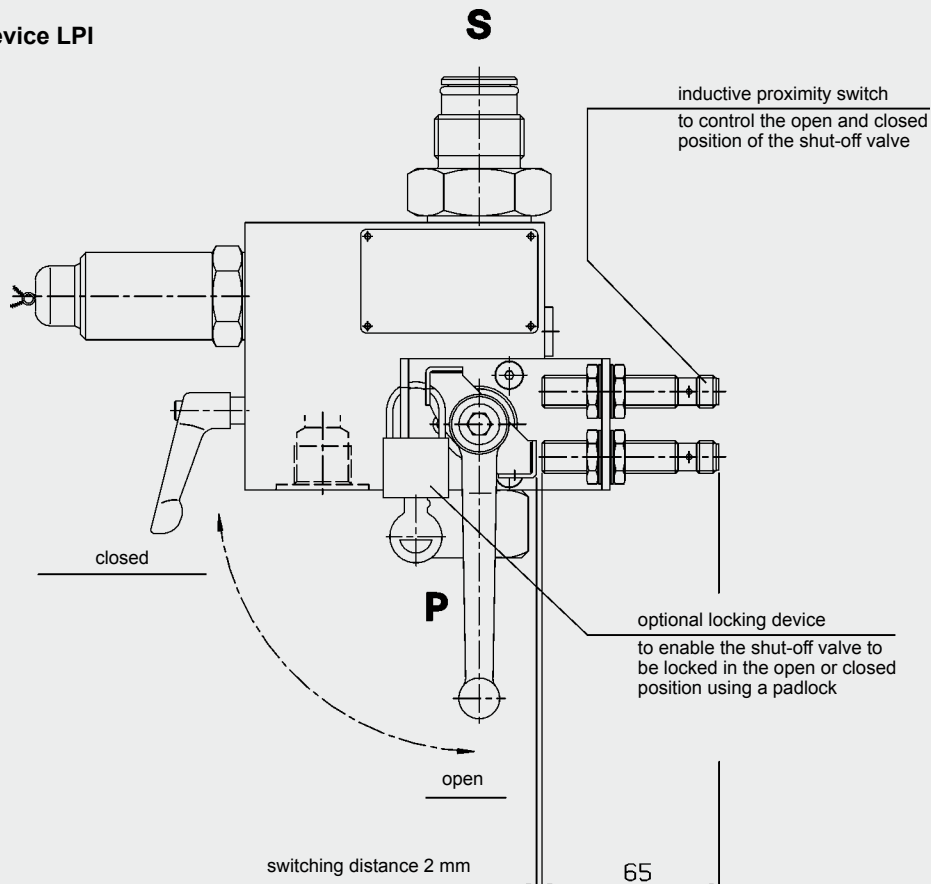

### 5.4.2 Additional device LPM

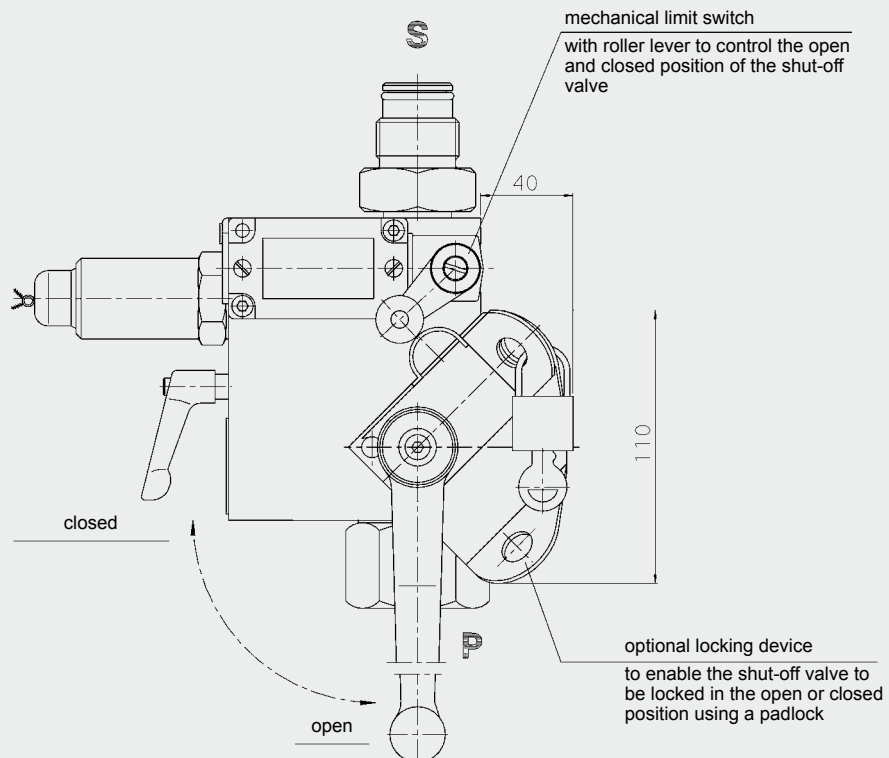

## 5.5. SAFETY AND SHUT-OFF BLOCK FOR FRONT PANEL MOUNTING

The safety and shut-off block consists of a valve block, a built-in pressure relief valve, a main shut-off valve and a manually operated pressure release valve.

This block is mounted on a front panel with 3 off M8 screws. Ports "P" and "T" are located on the mounting side.

### Advantages:

The compact design means that the block occupies a minimum of space and ensures minimum maintenance.

### Technical specifications:

Type:	SA6M10T...
Size:	DN10
Max. operating pressure:	350 bar
Direct operated pressure relief valve	size 6

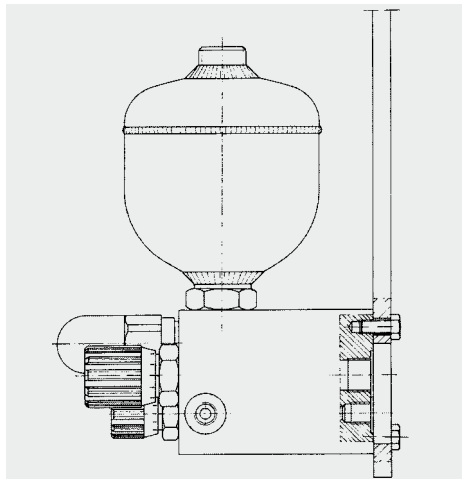
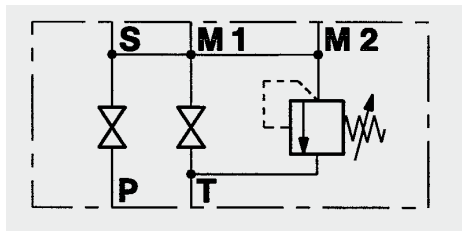

## 5.6. SAFETY AND SHUT-OFF BLOCK WITH 2-WAY CARTRIDGE VALVE (LOGIC ELEMENT)

This safety and shut-off block consists of a valve block, an integral pressure relief valve and a solenoid-operated 2-way cartridge valve which replaces the main shut-off valve.

### Advantages:

In addition to its compact construction, this model is capable of rapid switching to control the oil flow.

### 5.6.1 Function when using 4/2 directional valve

When the 4/2 directional valve is in the switching position shown (open when de-energised), the spring chamber of the logic element is pressurised via the accumulator pressure; the path from P to S is blocked and the hydraulic accumulator is automatically shut off from the system. By connecting the accumulator via the slip-in orifice in the pilot valve to the tank, it will slowly discharge.

When the 4/2 directional valve is in the crossed-over switching position (energised), the spring chamber of the logic element is discharged, the path from P to S is opened and the accumulator is charged.

### Technical specifications:

Model	Size	Max. operating pressure	Pressure relief valve <sup>1)</sup>
SA20A50T...	DN20	400 bar	size 12 (2)
SA32A50T...	DN30	400 bar	size 12 (3)
SA40A50T...	DN40	400 bar	size 12 (3)

<sup>1)</sup> number of pressure relief valves

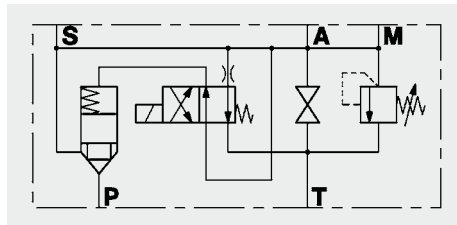

## 5.6.2 Function when using 3/2 directional poppet valve

When the 3/2 directional poppet valve is in the switching position shown (open when de-energised), the spring chamber of the logic element is pressurised via the system pressure; the path from P to S is blocked and the accumulator is shut off from the system. When the 3/2 directional poppet valve is in the discharge position (energised) the spring chamber of the logic element is discharged, the path from P to S is open and the accumulator is charged.

If the pump breaks down or if it is switched off, the 3/2 directional poppet valve reverts to the "open when de-energised" position; the accumulator pressure shuts off the logic element via the shuttle change-over valve and shuts off the accumulator from the system.

### Technical specifications:

Model	Size	Max. operating pressure	Pressure relief valve <sup>1)</sup>
SA20A51T...	DN20	400 bar	size 12 (2)
SA32A51T...	DN30	400 bar	size 12 (3)
SA40A51T...	DN40	400 bar	size 12 (3)

<sup>1)</sup> number of pressure relief valves

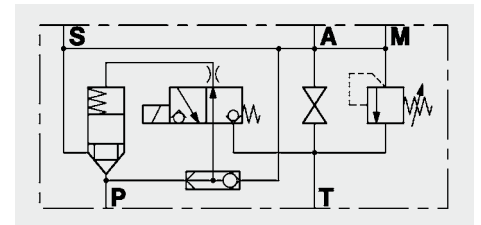

## 6. DESCRIPTION OF DSV10

### 6.1. GENERAL

#### DSV10 as a low cost alternative to the SAF10

The 3-way safety block DSV10 is used to shut off and discharge hydraulic accumulators or consumers. It complies with relevant safety standards in accordance with DIN EN 982 and the German industrial safety regulations BetrSichV.

The HYDAC pressure relief valve DB12 is used with the DSV series. This is a direct-operated pressure relief valve in poppet valve construction with excellent opening and closing characteristics.

This version of the DB12 complies with the requirements of the Pressure Equipment Directive 97/23/EC with CE marking. There are four different models:

- DSV10M, manual discharge, standard L-ball
- DSV10M-T-ball, manual discharge, T-ball
- DSV10EY, manual/solenoid-operated discharge, open when de-energised
- DSV10EZ, manual/solenoid-operated discharge closed when de-energised

The essential difference compared to the SAF10 lies in the shut-off and discharge function of the DSV10. On request we can supply other models to cover almost all applications, e.g. for aggressive media.

On request we can supply test certificates to EN 10204 and quality test certificates to DIN 55350, Part 18.

### 6.2. CONSTRUCTION

The DSV 3-way safety block consists of a valve block with an integral HYDAC pressure relief valve and a shut-off valve. It has ports for the pump, pressure gauge, tank and accumulator.

In addition, an optional solenoid-operated 2-way directional valve allows automatic discharge of the accumulator or consumer.

#### Accumulator operation

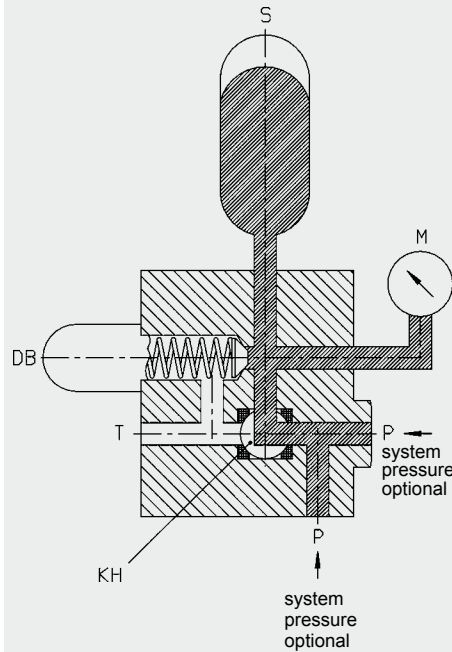

#### Shutting off the system pressure and simultaneously discharging the accumulator

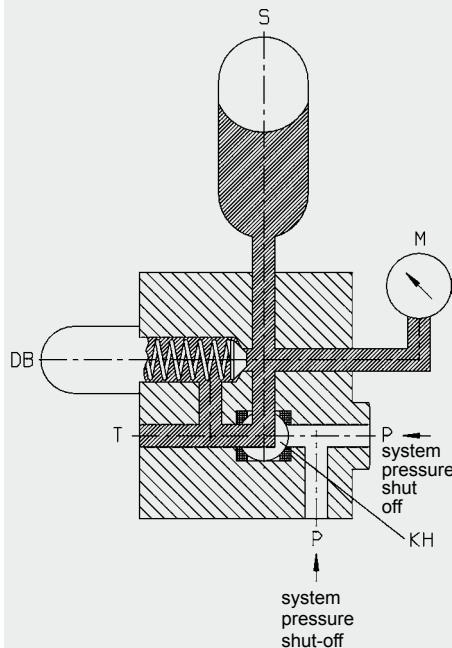

- P – Pump port
- S – Accumulator
- KH – Change-over ball valve
- DB – Pressure relief valve
- M – Pressure gauge port
- T – Tank port

The DSV10 can be used as a cost-effective alternative to the SAF10. Unlike the SAF10, the DSV10 shuts off when discharging simultaneously to the tank.

### 6.3. PORTS

The DSV has the following ports:

- S – Accumulator port (M33x2 DIN 3852 Part 3)
- P – Inline port (G 3/8 and G 1/2)
- T – Tank port (G 1/4)
- M – Pressure gauge port (G 1/4)

### 6.4. FUNCTION

When the accumulator is in operation the change-over ball valve connects the pump port with the accumulator. At the same time the accumulator is monitored for pressure via the built-in pressure relief valve. By switching over the ball valve, the pump port is shut off leakage-free on the inlet side and the accumulator is discharged simultaneously to the tank.

During switching all three ports (P, S and T) are momentarily interconnected (negative switching overlap). If a solenoid-operated 2/2 directional poppet valve is fitted, automatic discharge is possible (e.g. in the event of a power failure or shut-down).

### 6.5. NOTES

Ball valves are not designed to be used as flow control valves; therefore they should always be either fully open or fully closed, to avoid damaging the sealing cups.

To ensure correct functioning, pressure and temperature specifications must be observed.

## 6.6. SPECIFICATIONS

### 6.6.1 Symbols

DSV10M

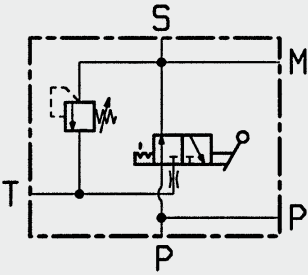

DSV10M-T-ball

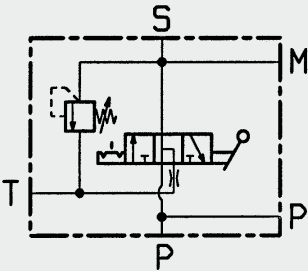

DSV10EY

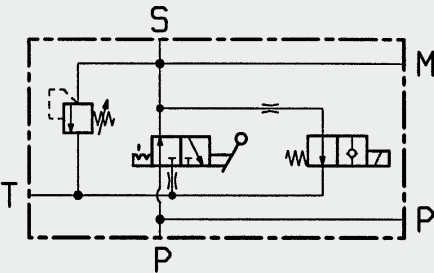

DSV10EZ

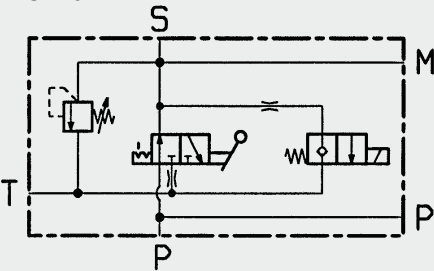

### 6.6.2 Type of construction

Ball valve isolating device

Pressure relief valve is direct-operated as a poppet valve

Poppet valve is pilot-operated

### 6.6.3 Materials

Housing and blanking plug in steel, surface protection: phosphate-plated.

Ball in steel, hard-chromed.

Pressure relief valve and poppet valve in high tensile steel, closing element in hardened and ground steel, wear-resistant, surface protection: phosphate-plated.

Ball seal in high quality synthetic material (POM)

Soft seals in Perbunan (NBR).

Cranked handle SW09 in red anodised aluminium.

### 6.6.4 Mounting position

Optional

### 6.6.5 Operating fluids

Mineral oil to DIN 51524

Part 1 and Part 2

(other fluids on request)

### Viscosity range:

Min. 10 mm<sup>2</sup>/s

Max. 380 mm<sup>2</sup>/s

### Filtration:

Max. permitted contamination of the operating fluid to SAE AS 4059 Class 11. We therefore recommend a filter with a minimum retention rate of  $\beta_{20} \geq 100$ . The fitting of filters and the regular replacement of filter elements guarantees correct operation, reduces wear and tear and increases the service life.

### 6.6.6 Permitted operating temperature

-10 °C ... +80 °C

(Ambient temperature for

E version is limited to

-10 °C ... +60 °C)

### 6.6.7 Maximum operating pressure

350 bar

### 6.6.8 $\Delta p - Q$ graph

measured at

$t_{oil} = 50 \text{ °C}$

$v = 30 \text{ mm}^2/\text{s}$

Flow rate from P to S

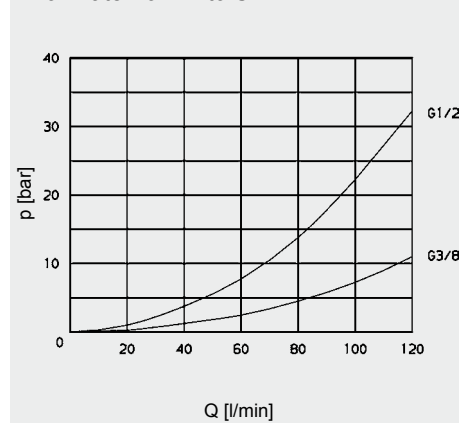

Flow rate from S to T

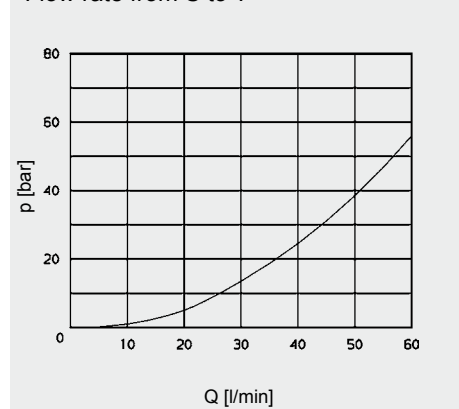

### 6.6.9 Model with solenoid-operated pressure relief

#### Type of operation

Solenoid-operated by means of pressure-tight, oil-immersed, single-stroke solenoids in accordance with VDE 0580. Actuating solenoid with male connector to DIN 43650, standard for general industrial applications, available for 24 V DC and 230 V AC.

#### Type of voltage

DC solenoid.

When connected to AC voltage the necessary DC voltage is produced by means of a bridge rectifier connector.

#### Voltage tolerance

±15 % of the nominal voltage

#### Nominal current

depending on the nominal voltage

24 V DC 0.80 A

230 V AC 0.11 A

#### Power consumption

$p_{20} = 18 \text{ W}$

#### Duty

100% = continuous operation

#### Switching time

Depending on the symbol, pressure across the individual ports and flow rate.

WSM06020Y:

On: 50 ms, Off: 35 ms

WSM06020Z:

On: 35 ms, Off: 50 ms

## 6.7. SPARE PARTS

Please see brochure:

- 3-way safety block - DSV No. 5.251

## 6.8. MODEL CODE FOR DSV10

(also order example)

DSV 10 M - 4 . 1 / 1 / X / T ... - G 24 - Z4 ...

3-way safety block

Nominal bore

10

Discharge

M = Manual discharge

E = Solenoid-operated and manual discharge

For solenoid-operated discharge  
with manual override, also indicate

Y = open when de-energised

Z = closed with de-energised

Type of pressure relief valve

4 = DB12

With/without fitted  
pressure relief valve

1 = with pressure relief valve

0 = without pressure relief valve

Accumulator connection

1 = M33x2

Series

(determined by manufacturer)

Setting of pressure relief valve

T = pressure-set and lead-sealed by TÜV

V = adjustable using tool

F = preset by manufacturer

x = no details (for model without relief valve cartridge)

Pressure setting

... = pressure setting

... = pressure range

xxx = no details (for model without relief valve cartridge)

Pressure setting range

DB12 – 150 bar

DB12 – 250 bar

DB12 – 350 bar

Type of voltage for solenoid

G = DC

W = AC

Voltage for solenoid

24 = 24 V for type G voltage

230 = 230 V for type W voltage

Type of connection for solenoid

Z4 = connector to DIN 43650 - AF2 - PG11

Supplementary details

T-ball = ball bore (180° switch)

Viton® (FKM) = O-ring seal

## 6.9. DIMENSIONS

### DSV10 3-way safety block

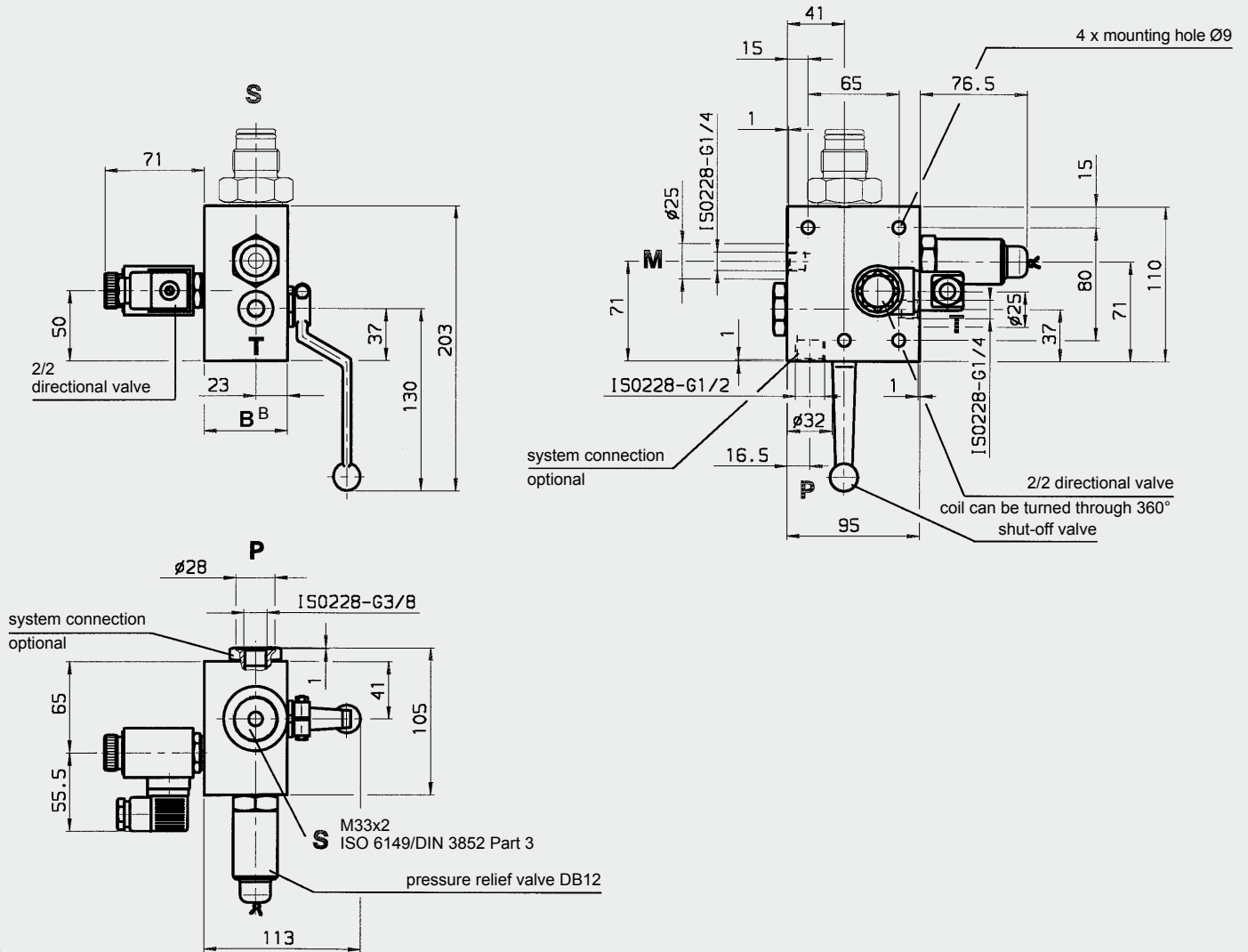

Model	B[mm]	Weight
DSV10M...	45	3.5 kg
DSV10E...	60	3.9 kg

#### DSV10 Standard models

Model	Part no.	Model	Part no.
DSV-10-M-4.0/1/X/XXXX	555999	DSV-10-EY-4.0/1/X/XXXX-G24-Z4	557367
DSV-10-M-4.1/1/X/T035	555968	DSV-10-EY-4.1/1/X/T035-G24-Z4	555980
DSV-10-M-4.1/1/X/T050	555969	DSV-10-EY-4.1/1/X/T050-G24-Z4	555981
DSV-10-M-4.1/1/X/T070	555970	DSV-10-EY-4.1/1/X/T070-G24-Z4	555982
DSV-10-M-4.1/1/X/T100	555971	DSV-10-EY-4.1/1/X/T100-G24-Z4	555983
DSV-10-M-4.1/1/X/T150	555972	DSV-10-EY-4.1/1/X/T150-G24-Z4	555984
DSV-10-M-4.1/1/X/T200	555973	DSV-10-EY-4.1/1/X/T200-G24-Z4	555985
DSV-10-M-4.1/1/X/T210	555974	DSV-10-EY-4.1/1/X/T210-G24-Z4	555986
DSV-10-M-4.1/1/X/T250	555975	DSV-10-EY-4.1/1/X/T250-G24-Z4	555987
DSV-10-M-4.1/1/X/T300	555976	DSV-10-EY-4.1/1/X/T300-G24-Z4	555988
DSV-10-M-4.1/1/X/T315	555977	DSV-10-EY-4.1/1/X/T315-G24-Z4	555989
DSV-10-M-4.1/1/X/T330	555978	DSV-10-EY-4.1/1/X/T330-G24-Z4	555990
DSV-10-M-4.1/1/X/T350	555979	DSV-10-EY-4.1/1/X/T350-G24-Z4	555991

## 7. ACCESSORIES: ADAPTERS FOR SAF/DSV10

### 7.1. ADAPTERS FOR LOW PRESSURE BLADDER ACCUMULATORS

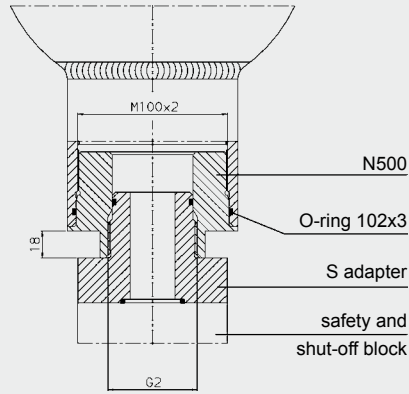

Model	Accumulator type	Volume [l]	Adapter	Part no. <sup>1)</sup> NBR/Carbon steel	Corresponding S - adapter	Part no. <sup>1)</sup> NBR/Carbon steel
SAF10/20 and DSV10	SB35	2.5 to 50l	N500	367229	S 13	369481
SAF32					S 309	366715

### 7.2 ADAPTERS FOR DIAPHRAGM ACCUMULATOR

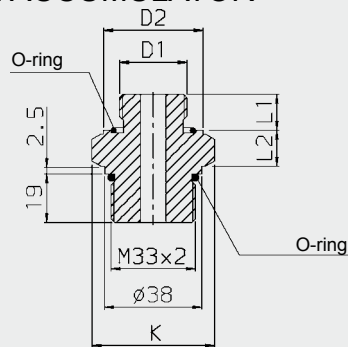

Model	Accumulator type	Volume [l]	D1 Thread	Part no. <sup>1)</sup> NBR/Carbon steel	Adapter	K SW	L1 [mm]	L2 [mm]	D2 [mm]	O-ring
SAF10/20 DSV10	SBO...E-	0.075 to 1.4l	G 1/2 A	369485	S 30	41	14	17.5	33	22x3
	SBO...A6-	0.1 to 210-1.3l								
	SBO...E-	2.0 to 3.5l	G 3/4 A	369486	S 31	16	40	40	28x3 35x3	
	SBO...A6-	1.3 to 4l								

<sup>1)</sup> Others on request

### 7.3 ADAPTERS FOR PISTON ACCUMULATOR

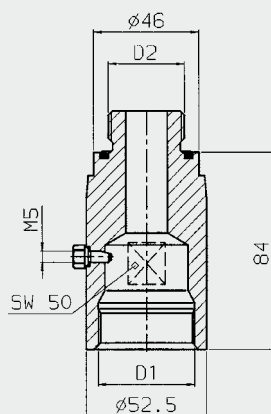

Diagram 1

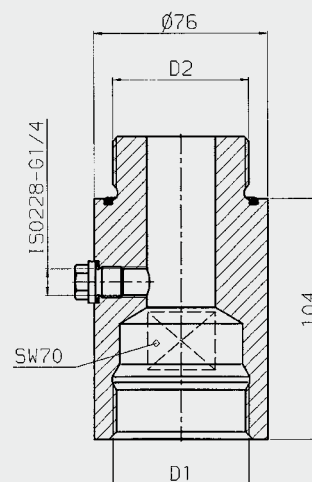

Diagram 2

Model	Accumulator type	Volume [l]	Adapter	Part no. <sup>1)</sup> NBR/Carbon steel	Diag.	D1 [mm]	D2 [mm]	O-ring	Corresponding S adapter	Part no. <sup>1)</sup> NBR/Carbon steel
SAF10/20 DSV10	SK210/350 -	2.5 to 7.5	K 406	374929	1	G 1 1/4	G 1	35x3	S 12	369480
	SK210/350 -	10 to 45	K 408	374931	2	G 2	G 1 1/2	53x3	S 13	369481
SAF32	SK210/350 -	50 to 120	K 409	374933			G 2	62x3	S 309	366715

<sup>1)</sup> Others on request.

## 7.4. TO CONNECT THE SAFETY AND SHUT-OFF BLOCK WITH THE ACCUMULATOR

Adapters for standard bladder accumulator

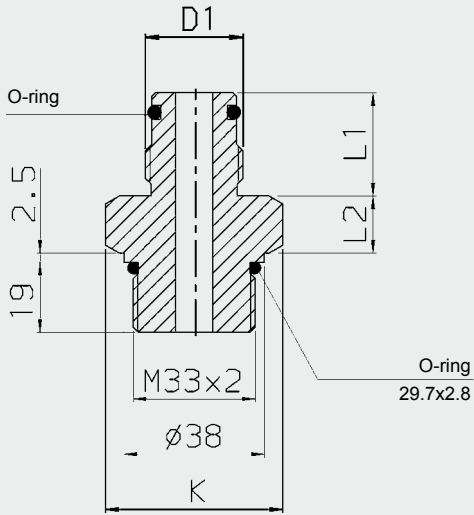

Diagram 1

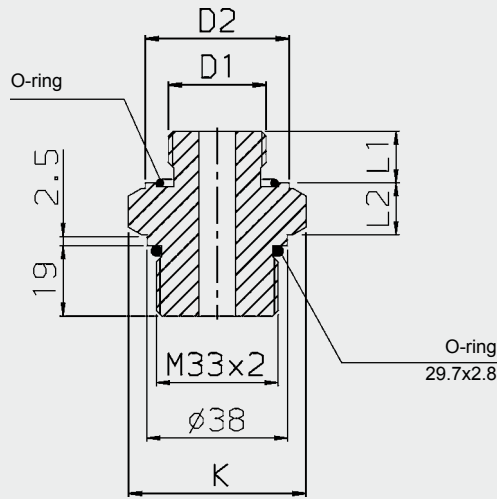

Diagram 2

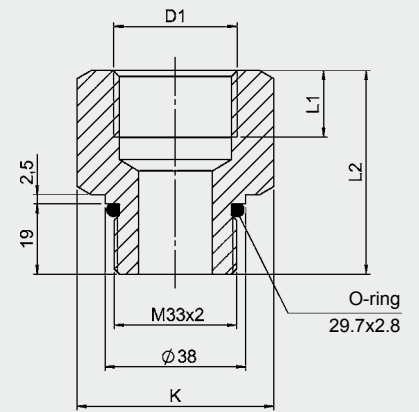

Diagram 3

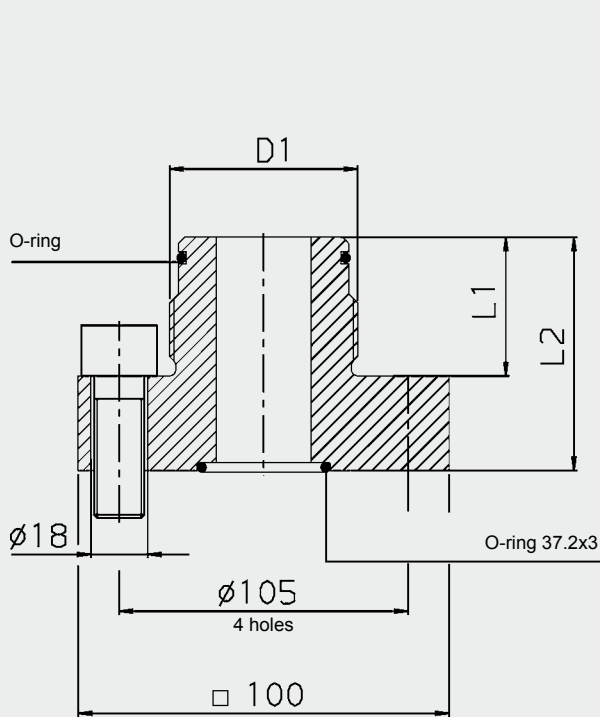

Diagram 4

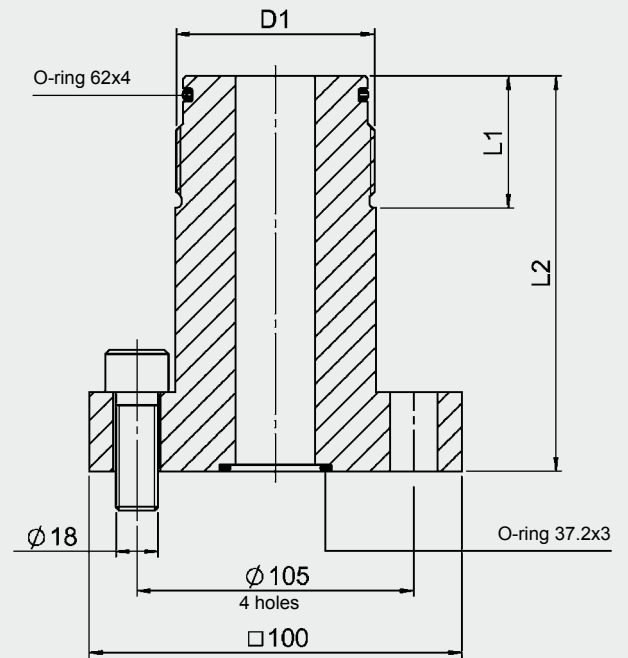

Diagram 5

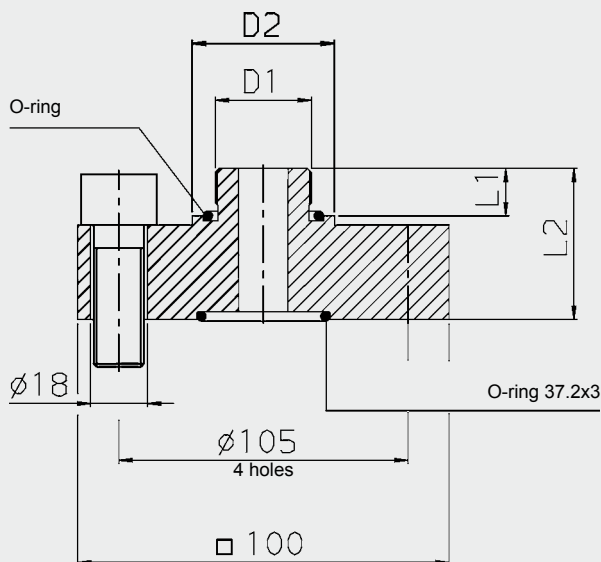

Diagram 6

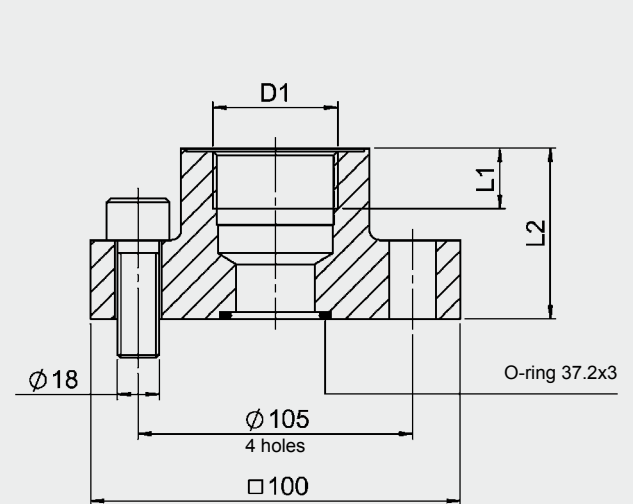

Diagram 7

Model	Accumulator type	Volume [l]	D1 Thread	Adapter	Part no. <sup>2)</sup> NBR/Carbon steel	Diag.	K SW [mm]	L1 [mm]	L2 [mm]	D2 [mm]	O-ring [mm]	
SAF10 SAF20 DSV10	SB330/400-	0.6 ... 1	G 3/4A	S 10	00369479	1	41	28	16		17x3	
	SB550/600-	1 ... 5	G 1A	S 11	00372750		46	34	17		22x3	
	SB330/400-	2.5 ... 5	G 1 1/4A	S 12	00369480		37				30x3	
	SB330/400-	10 ... 50	G 2A	S 13	00369481		65	44	21		48x3	
	SB550/600-	10 ... 50										
	Connection with metric fine thread			M30x1.5	S 20	00369482	2	41	15	18	40	32x2
				M40x1.5	S 21	00369483		55	20	21	54	43x3
				M50x1.5	S 22	00369484		65			64	53x3
	SB330/400-	2.5 ... 50	G 3/4	S 367861	00369489	3	41	18	50			
			G 1	S 379766	00369490		46	20	55			
G 1 1/4			S 379767	00369498	65		22	60				
SAF32	SB330/400-	0.6 ... 1	G 3/4A	S 305 <sup>1)</sup>	0036672	4		28	58		17x3	
	SB550/600-	1 ... 5	G 1A	S 306 <sup>1)</sup>	02102855			34	64		22x3	
	SB330/400-	2.5 ... 5	G 1 1/4A	S 307 <sup>1)</sup>	00366724			37	67		30x3	
	SB330/400-	10 ... 50	G 2A	S 309 <sup>1)</sup>	00366715			44	74		48x3	
	SB550/600-	10 ... 50		S 308 <sup>1)</sup>	00376813		115					
	SB330H-	10 ... 50	G 2 1/2A	S 365922	00377283	5		50	150		62x4	
	Connection with metric fine thread			M30x1.5	S 330 <sup>1)</sup>	00366735	6		15	47	45	32x2
				M40x1.5	S 340 <sup>1)</sup>	00366736			20	51	60	43x3
				M50x1.5	S 350 <sup>1)</sup>	00366737					75	53x3
	SB330/400-	10 ... 50	G 1	S 365637	02106583	7		20	60			
G 1 1/4			S 369658	02106578			22					
G 1 1/2			S 237838	02103869			24	65				

<sup>1)</sup> Adapter supplied with 4 off hex. socket cap screws M16x45 (part no. 6032726) Torque 130 Nm

<sup>2)</sup> Others on request

## 8. NOTE

The information in this brochure relates to the operating conditions and applications described.

For applications and operating conditions not described, please contact the relevant technical department.

Subject to technical modification.

**HYDAC** Technology GmbH  
 Industriegebiet  
**D-66280 Sulzbach/Saar**  
 Tel.: 0 68 97 / 509 - 01  
 Fax: 0 68 97 / 509 - 464  
 Internet: www.hydac.com  
 E-Mail: speichertechnik@hydac.com

