

# Energy 2180 - DIP SWITCH

Code: 22172515-39

## GENERAL INFORMATION

Article	Energy 2180 - DIP SWITCH
Code	22172515-39

## DIMENSIONS AND WEIGHT

Height (mm)	58 mm
Diameter (Ø) (mm)	180 mm
Weight (Kg)	0.4 kg

## INSTALLATION

Min. recessed cut-out hole (mm)	160 mm
Max. recessed cut-out hole (mm)	175 mm

## ELECTRICAL CHARACTERISTICS AND CONTROLS

Voltage type	AC
Min Voltage (V)	220 V
Max Voltage (V)	240 V
Min Frequency (Hz)	50 Hz
Max Frequency (Hz)	60 Hz
Frequency (Hz)	50 Hz
Wiring name	CLD
Power factor	≥0.95
Rated Current	400 mA
Insulation class	Class II
Controllability	None



Fosnova offers a wide range of recessed spotlights to meet the increasingly demanding lighting needs of shopping centres, stores and museums. Extremely easy to maintain and install, combined with great versatility given by the various sizes, these spotlights can easily meet multiple needs. In particular, you can replace the system without intervening on the pre-existing structures.

DIP switch adjustment: the luminaire is equipped with a built-in DIP switch driver for setting the output current; this will enable to choose the right light flux for each lighting design.

The chance to choose the needed LED pilot current will allow you to have the right amount of power adjusted to any given design requirement. Choosing a lower current will increase the efficiency and improve energy savings, while a higher current will provide more light and make it possible to reduce the number of luminaires installed.



# Energy 2180 - DIP SWITCH

Code: 22172515-39

## PHOTOMETRIC DATA

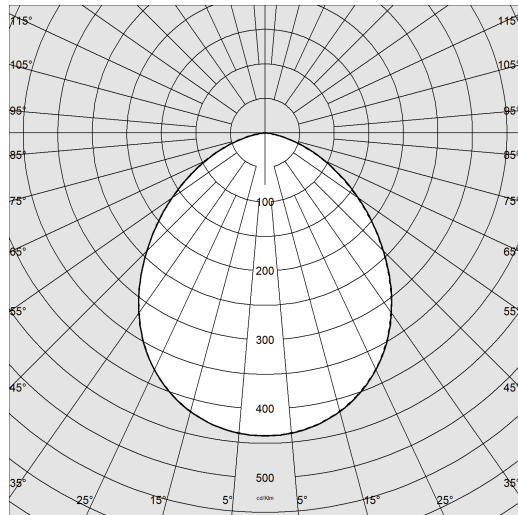

Lighting source	LED
CRI	95
Luminous flux (output) (lm)	1702 lm
Power absorption (total) (W)	14.4 W
CCT	3000 K
Luminous efficacy (lm/W)	118 lm/W
Low Flicker	luminaire with very low flicker: evenly distributed light for greater visual safety.
LED flux maintenance	50000 hr, L 90, B 10

## MECHANICAL CHARACTERISTICS

Impact resistance rating (IK)	IK07
IP (vl)	44
IP (va)	20

# Energy 2180 - DIP SWITCH

Code: 22172515-39

## MATERIALS AND COLOURS

Housing	in die-cast aluminium with springs for recess mounting.
Diffuser	thermoplastic material resistant to high temperatures.
Heat sink	built-in.
Coating	epoxy polyester powder coating resistant to UV rays.
Colour	White
Equipment	galvanised steel wire springs for false ceiling mounting.
CASAMBI version: fixtures to be installed in NON metallic false ceilings/panels.	

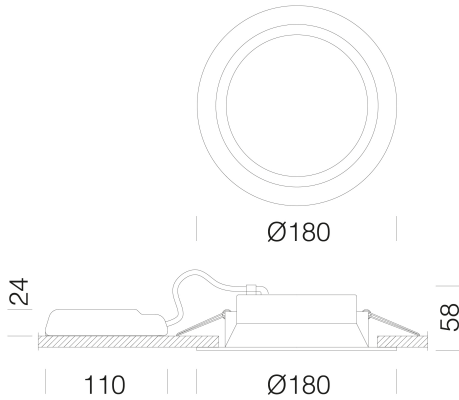

## STANDARDS AND COMPLIANCE

Photobiological safety class	RG0
Markings and tests	CE, ENEC
Reference standards	EN60598-1. With degree of protection according to EN60529.
Energy Label	E

## DOWNLOAD

### MOUNTS

[AssemblyInstructions Kit EM Acc-960xx rev5 12-23.pdf](#)

[AssemblyInstructions Dip switch 0523.pdf](#)

[AssemblyInstructions ENERGY rev13.pdf](#)

### DESIGNS

[BIM Energy 2180 05-24.zip](#)

[TechnicalDrawing 2180s.dxf](#)



## WARRANTY

After sales warranty 5 yr

## Energy 2180 - DIP SWITCH

---

Code	LED	TotW	K - Lumen Output - CRI
22172515-00	250	9	4000K - 1147lm - CRI 95
22172515-00	350	13	4000K - 1607lm - CRI 95
22172515-00	400	14	4000K - 1830lm - CRI 95
22172515-00	500	19	4000K - 2247lm - CRI 95
22172515-39	250	9	3000K - 1097lm - CRI 95
22172515-39	350	13	3000K - 1536lm - CRI 95
22172515-39	400	14	3000K - 1702lm - CRI 95
22172515-39	500	19	3000K - 2135lm - CRI 95

---

## Energy 2180 - DIP SWITCH

---

Code: 22172515-39

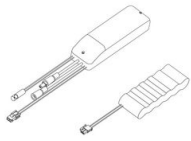

**EM Kit R**



**Safety cord**