

*Electrical interface document for saloon*

**AMSTERDAM**

COPRIGHT BY SHANGHAI FAIVELEY RAILWAY  
TECHNOLOGY Co. Ltd

Essential parts of this document are copyrighted and all the rights are reserved.

This document may not, in whole or in part, be copied, photocopied or reproduced without written permission from

SHANGHAI FAIVELEY RAILWAY TECHNOLOGY Co. Ltd

Release History



# AMSTERDAM

Document: KS97- EID

Revision: 09

Page 2/14

	name	Department	Date	Signature
Prepared by	Shen pingping	EHD	2010.04.13	
Checked by				
Checked by				
Released by				

## Revision Table

Revision	Date	Revised section,
02	2010-05-21	Add hardwire signal "Authorization ventilation" interface "T02/52"
03	2010-06-01	Change weidmuller to Harting
04	2010-06-03	Cancel the terminal for "Authorization ventilation"
05	2010-06-17	Change some connectors according customer's requirement
06	2010-06-25	Change H+S cable to Nexans cable
07	2010-07-29	Change -CN1,-CN2,-CN4 and I/O
08	2011-02-15	Delete pin B2 in connector -CN1
09	2011-06-27	Use the "O" type contact required by ALSTOM

## Distribution List

--	--	--

1. Interface –CN1 (Harting plug 400V-3-50Hz Power supply saloon).....	4
2. Interface –CN2 (Harting plug DC110V Power supply ).....	6
3. FPC08 unit plug –CN3 (Harting plug female ,CAN).....	8
4. FPC08 unit plug –CN5 (Harting plug male,CAN).....	9
5. Plug –CN4 (USB plug ,RS232).....	10
6.Interface of controller FPC08.....	11
6.1 Digital inputs/output (AMP_DI_DO_P3) .....	11
6.2 Analogue inputs (AMP_AI_P2).....	12
6.3 Power supply (AMP_P1) .....	13
7. DIO08 (WAGO TERMINAL ,X1、 X2、 X4、 X5、 X6、 X7).....	14

## 1. Interface –CN1 (Harting plug 400V-3-50Hz Power supply saloon)

-CN1						minimal
Pin	to device		No. wire control panel	No. wire unit	nominal current [A]	cross-section [mm <sup>2</sup> ]
A1	Power supply saloon	ROCKCLASSIC Module		101	43.3	16.0
A2	Power supply saloon			102	43.3	16.0
B1	Power supply saloon			103	43.3	16.0
B2	Reserve					
4		3	Number of pins with 1 reserve			

The colour of cable inside of the VAC unit is black, wires are white or black, protective groundings are green-yellow

Configuration of connection (ALSTOM, SFRT): piece page (Harting Rockstar)

ALSTOM: car side

SFRT: unit side

Plug: ROCKCLASSIC

Frame for 3 modules: 09 14 010 0303 1 06.11

Hood(top entry): 1xM25 19 30 010 0436 1 31.43

Module: Female 09 14 002 2741 2 06.19

Fill stuff: 09 14 000 9950 1

Socket: ROCKCLASSIC

Frame for 3 modules: 09 14 010 0313 1 06.11

Housing: 09 30 010 0302 1 31.43

Module : Male 09 14 002 2641 2 06.19

Fill stuff: 09 14 000 9950 1

Contact arrangement: view from termination side housing (from control panel)

=>

1 ... 3

=>

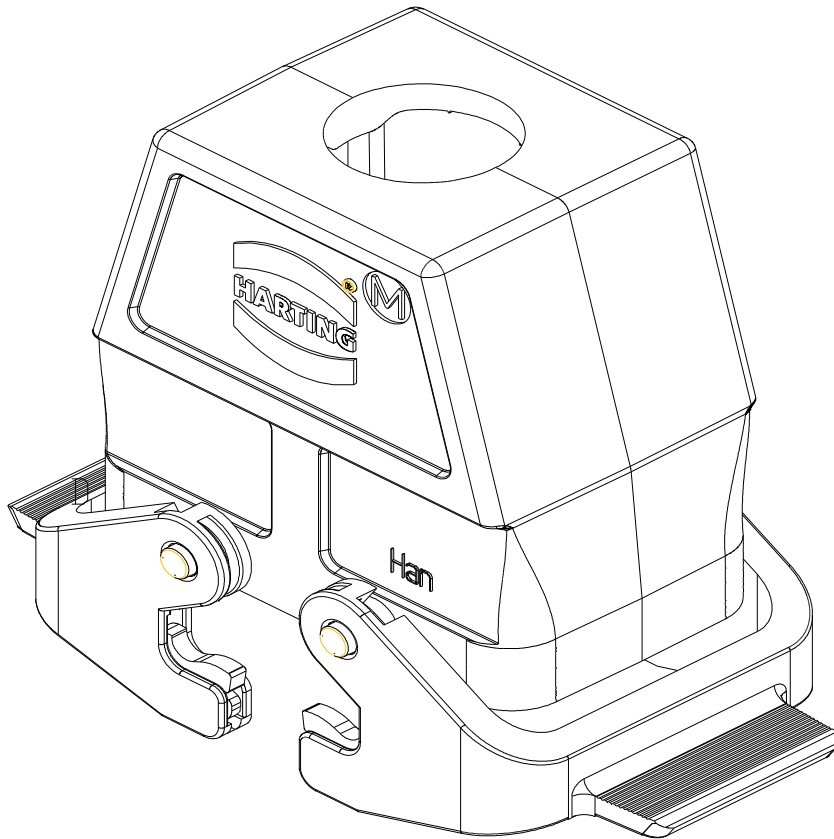
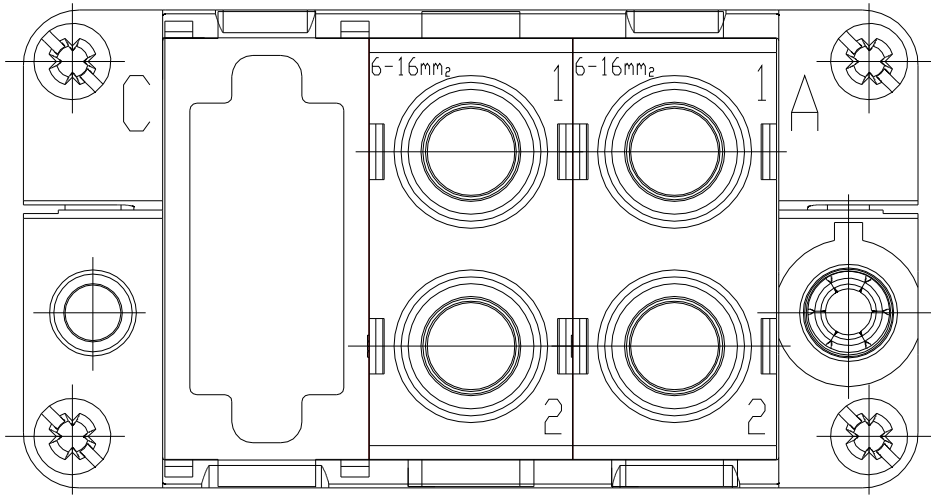

## 2. Interface –CN2 (Harting plug DC110V Power supply )

-CN2						minimal
Pin	to device		No. wire control panel	No. wire unit	nominal current [A]	cross-section [mm <sup>2</sup> ]
A1	DC110V power supply	ROCKCLASSIC Module		241		1,5
A2	DC110V power supply			242		1.5
A3	Reserve					
A4	Reserve					
A5	Reserve					
A6	Authorization ventilation				720	
6	3	Number of pins with 3 reserve				

The colour of cable inside of the VAC unit is black, wires are white or black, protective groundings are green-yellow

Configuration of connection (ALSTOM, SFRT):                      piece    page (Harting Rockstar)

ALSTOM: car side

SFRT:    unit side

Plug:                      ROCKCLASSIC

Frame for 3 modules:	09 14 010 0303	1	06.11
Hood(top entry): 1xM20	19 30 010 1430	1	31.43
Module:            Female	09 14 006 3101	1	06.31
Fill stuff:	09 14 000 9950	2	
Contact:            Female	09 33 000 6204	2	06.31
Contact:            Female	09 33 000 6205	1	06.31

Socket:                      ROCKCLASSIC

Frame for 3 modules:	09 14 010 0313	1	06.11
Housing:	09 30 010 0302	1	31.43
Module :            Male	09 14 006 3001	1	06.31
Fill stuff:	09 14 000 9950	2	
Contact:            Male	09 33 000 6104	2	06.31
Contact:            Male	09 33 000 6105	1	06.31

Contact arrangement: view from termination side housing (from control panel)

=>

1            ...            6

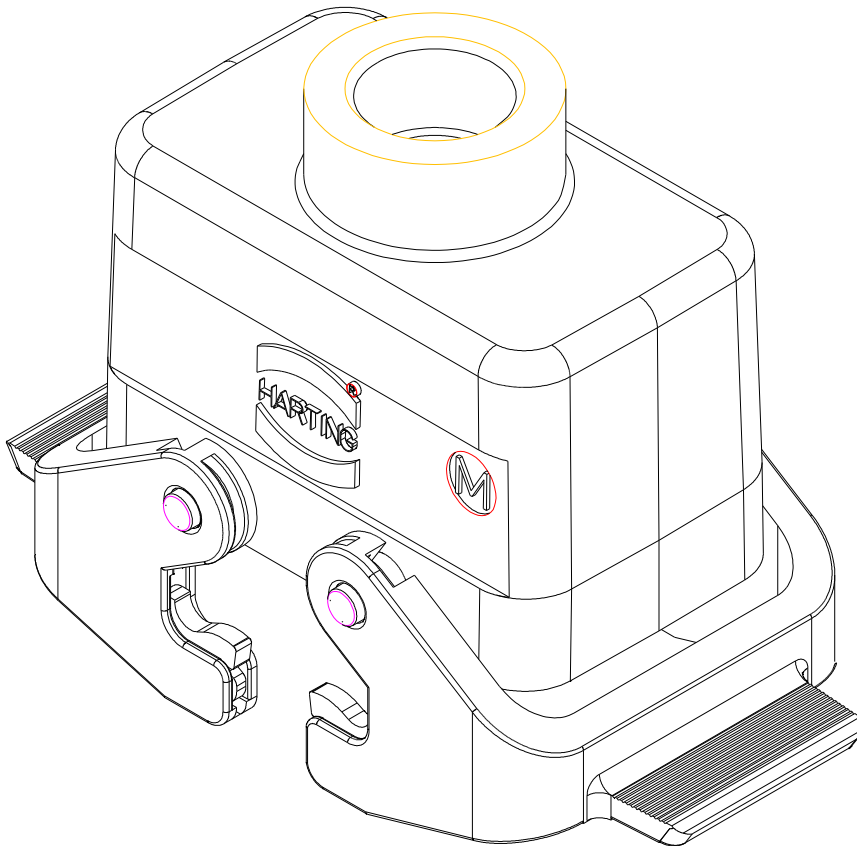
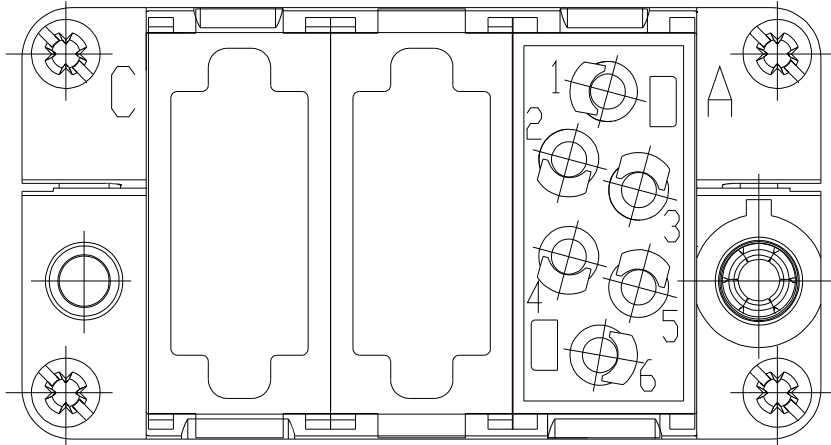

### 3. FPC08 unit plug –CN3 (Harting plug female ,CAN)

Pin	to device		No. wire control panel	No. wire unit	nominal current [A]	minimal cross-section [mm <sup>2</sup> ]
1		D-SUB				
2	-CAN				<1	0.5
3	0VCAN				<1	0.5
4						
5						
6						
7	+CAN				<1	0.5
8						
9						
CH	Screen					
9	3	Number of pins with 6 reserve				

The cable type is: TWINAX 2X0.5 120 OHMS+1X0.5 (Nexans) screen should be connect to the harting housing!

Configuration of connection ([ALSTOM](#), SFRT): piece page (Harting 11-2)

[ALSTOM](#): car side

SFRT: unit side

plug: D-SUB

Top entry hood	61 03 001 3010	1	06.09
Crimp contact (male)	61 03 000 0073	3	02.30
Crimp terminal (male)	09 67 009 5601	1	09.12
Crimp flange	61 03 000 0066	1	09.08
Crimp ferrule	61 03 000 0051	1	09.08

socket: D-SUB

Top entry hood	61 03 001 3010	1	06.09
Crimp contact (female)	61 03 000 0074	3	02.30
Crimp terminal (female)	09 67 009 4701	1	09.12
Crimp flange	61 03 000 0066	1	09.08
Crimp ferrule	61 03 000 0051	1	09.08

## 4. FPC08 unit plug –CN5 (Harting plug male,CAN)

-CN5						minimal
Pin	to device		No. wire control panel	No. wire unit	nominal current [A]	cross-section [mm <sup>2</sup> ]
1		D-SUB				
2	-CAN				<1	0.5
3	0VCAN				<1	0.5
4						
5						
6						
7	+CAN				<1	0.5
8						
9						
CH	Screen					
9	3	Number of pins with 6 reserve				

The cable type is: TWINAX 2X0.5 120 OHMS+1X0.5 (Nexans) screen should be connect to the harting housing!

Configuration of connection ([ALSTOM](#), SFRT): piece page (Harting 11-2)

[ALSTOM](#): car side

SFRT: unit side

plug: D-SUB

Top entry hood	61 03 001 3010	1	06.09
Crimp contact (female)	61 03 000 0074	3	02.30
Crimp terminal (female)	09 67 009 4701	1	09.12
Crimp flange	61 03 000 0066	1	09.08
Crimp ferrule	61 03 000 0051	1	09.08

socket: D-SUB

Top entry hood	61 03 001 3010	1	06.09
Crimp contact (male)	61 03 000 0073	3	02.30
Crimp terminal (male)	09 67 009 5601	1	09.12
Crimp flange	61 03 000 0066	1	09.08
Crimp ferrule	61 03 000 0051	1	09.08

5. Plug –CN4 (USB plug ,RS232)

-CN4						minimal
Pin	to device		No. wire control panel	No. wire unit	nominal current [A]	cross-section [mm <sup>2</sup> ]
1		D-SUB			<1	0.5
2					<1	0.5
3					<1	0.5
4					<1	0.5
4	4	Number of pins with 0 reserve				

## 6.Interface of controller FPC08

### 6.1 Digital inputs/output (AMP\_DI\_DO\_P3)

#### 1. FPC08

Pin	to device	No. wire unit	maximal (!!!) cross-section [mm²]
P3_12_DI_01	PWR	720	1.0
P3_13_DI_02	Feedback HP1	223	1.0
P3_14_DI_03	Feedback HP2	231	1.0
P3_15_DI_04	SAF emergency ventilation contactor KM17 feedback	628	1.0
P3_16_DI_05	Compressor1 OK	609	1.0
P3_17_DI_06	Compressor2 OK	610	1.0
P3_18_DI_07	heater 1 contactor KM18 feedback	611	1.0
P3_19_DI_08	heater 2 contactor KM19 feedback	612	1.0
P3_05_DO_01	Compressor1	711	1.0
P3_04_DO_02	Compressor2	712	1.0
P3_03_DO_03	Condenser fan1	533	1.0
P3_02_DO_04	Condenser fan2	537	1.0
P3_07_DO_05	SAF high speed	543	1.0
P3_08_DO_06	SAF low speed	547	1.0
P3_09_DO_07	Reserve		
P3_10_DO_08	FPC ok	903	1.0
16	15	Number of Pins (with 1 reserve)	
Requested opposite parts of plug:			
Ordering number	Description	Supplier	Piece
VAGO			
734-220 / 000-300	Plug male 20 pin	VAGO	1
			SFRT-reference

## 6.2 Analogue inputs (AMP\_AI\_P2)

### 1. FPC08

Pin	To device		No. wire unit	maximal (!!!) cross-section [mm²]
P2_6/13_AI_01	Fresh air temp.sensor(unit)	shielded	424/425	0.75
P2_8/7_AI_02	return air temp. sensor(unit)	shielded	427/428	0.75
P2_10/11_AI_03	supply air temp.sensor(unit)	shielded	430/431	0.75
P2_12/5_AI_04	Power normal operation detection	shielded	450/451	0.75
P2_14/9_AI_05	Power emergency operation detection	shielded	453/454	0.75
P2_16/4_AI_06	Reserve			
	6	5	Number of Pins (with 1 reserve)	
Ordering number VAGO	Description	Supplier	Piece	SFRT-reference
734-216/000-300	Plug male 16 pin	VAGO	1	

### 6.3 Power supply (AMP\_P1)

#### 1. FPC08

				maximal (!!!)
Pin	To device		No. wire unit	cross-section [mm <sup>2</sup> ]
P1_1_supply(-)minus	DC 110V (-)		990	1.0
P1_2_supply(+)plus	DC 110V (+)		254	1.0
2		2	Number of Pins (totally and without reserve)	
Ordering number VAGO	Description	Supplier	Piece	SFRT-reference
734-202/037-300	Plug male 2 pin	VAGO	1	

## 7. DIO08 (WAGO TERMINAL ,X1、 X2、 X4、 X5、 X6、 X7)

Configuration of connection (SFRT):

WAGO terminal	piece
X1 : Connector: 231-302/026-000 2pol. Ping spacing 5,08mm	1
X2: Connector: 231-304/026-000 4pol. Ping spacing 5,08mm	1
X4: Connector: 231-306/026-000 6pol. Ping spacing 5,08mm	1
X5: Connector: 231-306/026-000 6pol. Ping spacing 5,08mm	1
X6: Connector: 231-305/026-000 5pol. Ping spacing 5,08mm	1
X7: Connector: 231-305/026-000 5pol. Ping spacing 5.18mm	1

### DIO08 (X1-X7)

Pin	to device	No. wire unit	maximal (!!!) cross-section [mm²]
X1_1	DC power plus	256	1,0
X1_2	DC power minus	253	
X2_3_CH	Can+	Can+	0.5
X2_4_CL	Can-	Can-	0.5
X4_1_DO_04	Hot gas bypass solenoid2	346	1.0
X4_2_OC	Reference+	258	1.0
X4_3_DO_03	Hot gas bypass solenoid1	345	1.0
X4_4_DO_02	Fresh air damper	364	1.0
X4_5_OC	Reference+	259	1.0
X4_6_DO_01	Return air damper	409	1.0
X5_1_DO_05	emergency ventilation	810	1.0
X5_2_OC	Reference+	472	1.0
X5_3_DO_06	heater group 1	820	1.0
X5_4_DO_07	heater group 2	821	1.0
X5_5_OC	Reference+	471	1.0
X5_6_DO_08	Reserve		
X6_1_DI_04	Feedback LP2	254	1.0
X6_2_DI_03	Feedback LP1	252	1.0
X6_3_DI_02	SAF low speed ok	623	1.0
X6_4_DI_01	SAF high speed ok	613	1.0
X6_5_IC	Reference-	377	1.0
X7_1_IC	Reference-	376	1.0
X7_2_DI_05	Fresh air damper 1&2 feedback	361	1.0
X7_3_DI_06	Feedback of Condenser fan 1+2	652	1.0
X7_4_DI_07	Feedback of R.A.D	443	1.0
X7_5_DI_08	Heater overload	670	1.0