

ASTRON / INAF

RCU2H toplevel

DESIGN		REV	
A3	Filename	RCU2_DIG	3.1
DRAWN BY Sieds / Gijs	SHEET 1 of 76	DATE	08/04/2022:13:16

1

2

3

4

5

E

D

C

B

A

ASTRON			
DESIGN <TITLE>			
SIZE A3	Filename RCU2_DIG	REV 3.1	
DRAWN BY Sieds / Gijs	SHEET 2 of 76	DATE 08/04/2022:13:16	

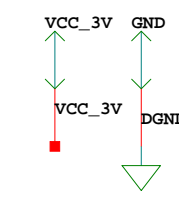
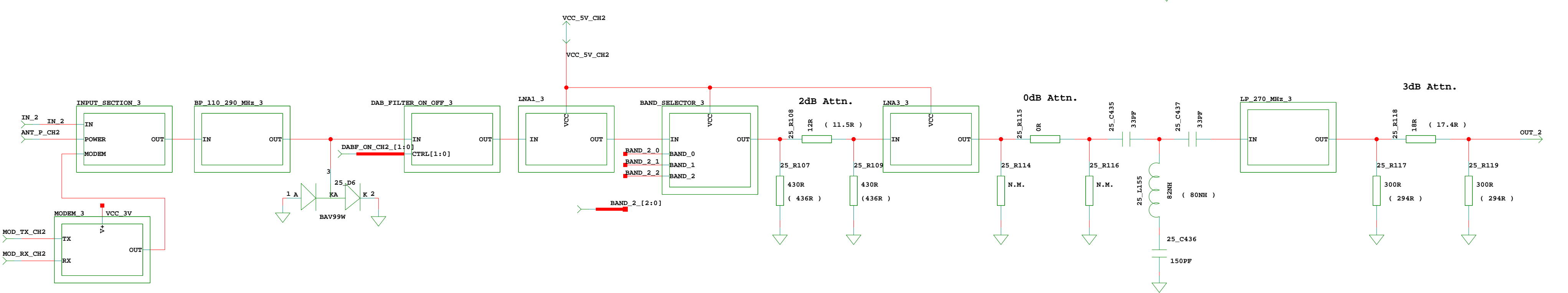
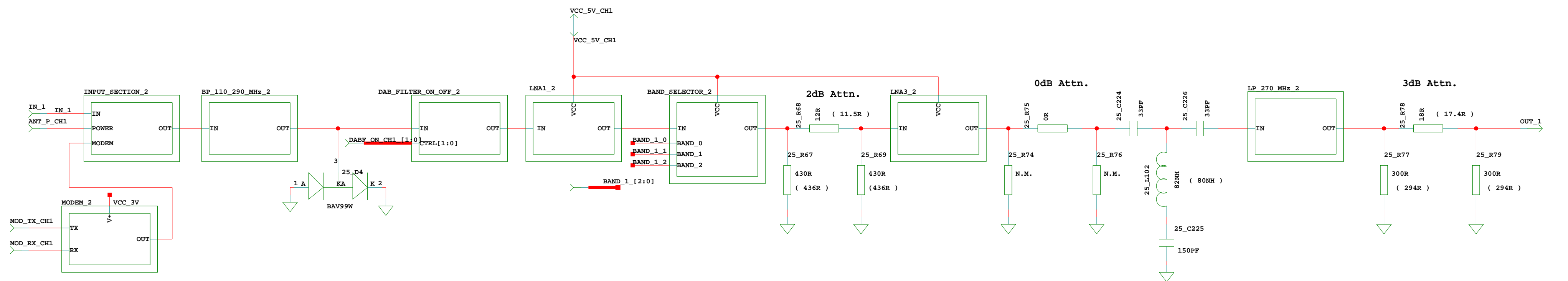
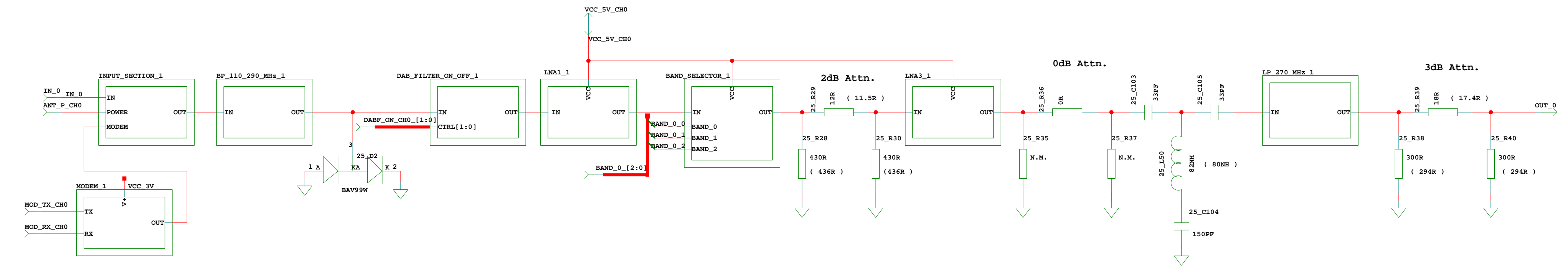

ASTRON / INAF

ASTRON			
DESIGN <TITLE>			
SIZE A1	Filename 2	RCU2_HB	REV 3.1
DRAWN BY Sieds / Gijs	SHEET 3 of 76	DATE	08/04/2022:13:17

REVISIONS RCU3_HB

16/07/2020
— FIRST EMISSION

ASTRON			
DESIGN <TITLE>			
SIZE A1	Filename 1	RCU2_HB	REV 3.1
DRAWN BY Sieds / Gijs	SHEET 4 of 76	DATE 08/04/2022:13:16	

1

2

3

4

5

E

D

C

B

A

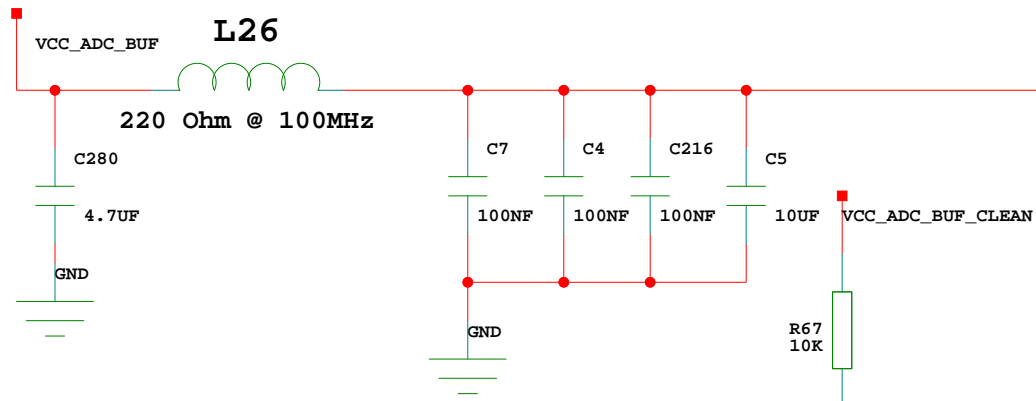

Decoupling of ADA, place close to the pins

Double Swap for layout

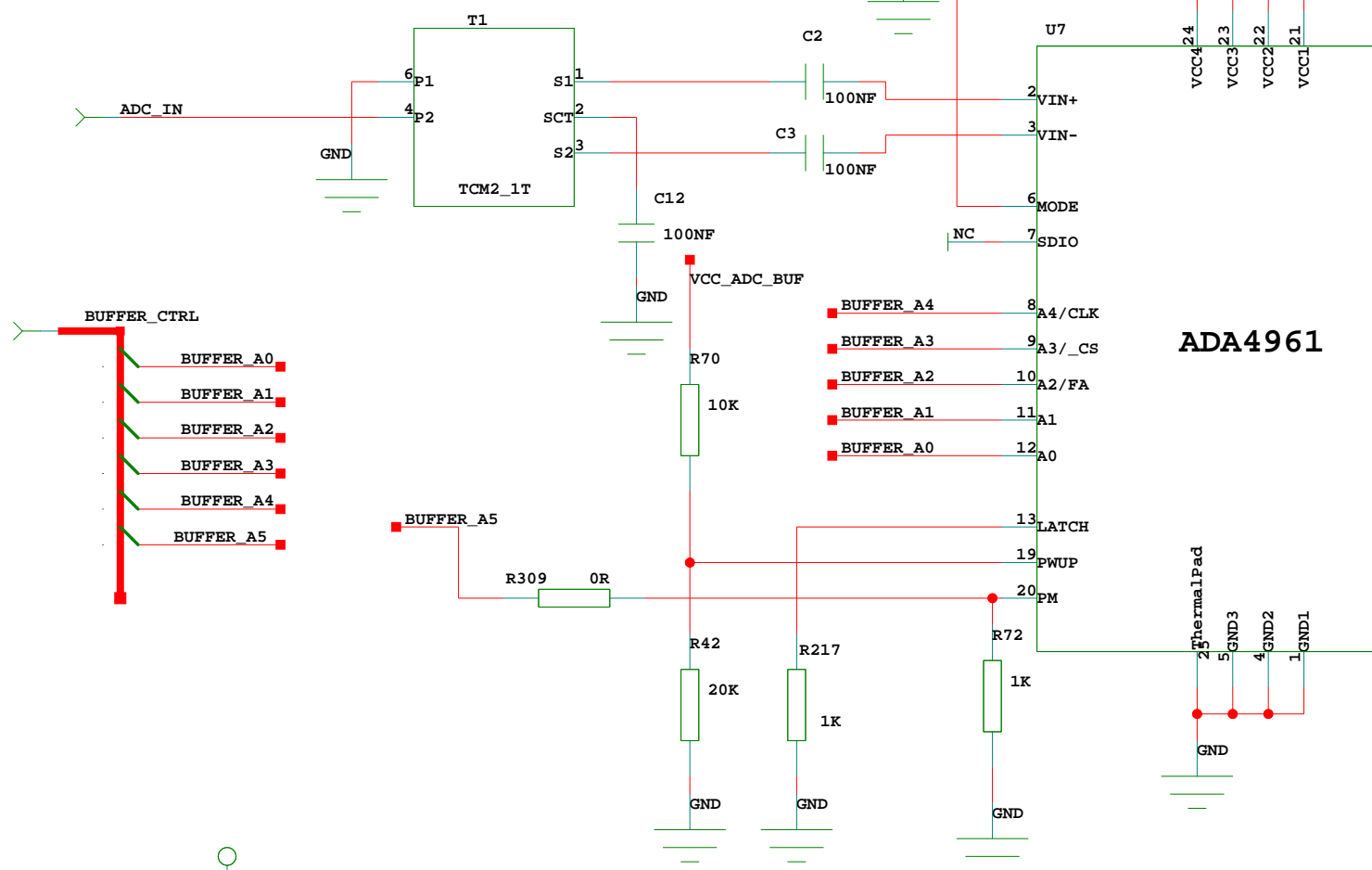

ADA4961

0.77 W

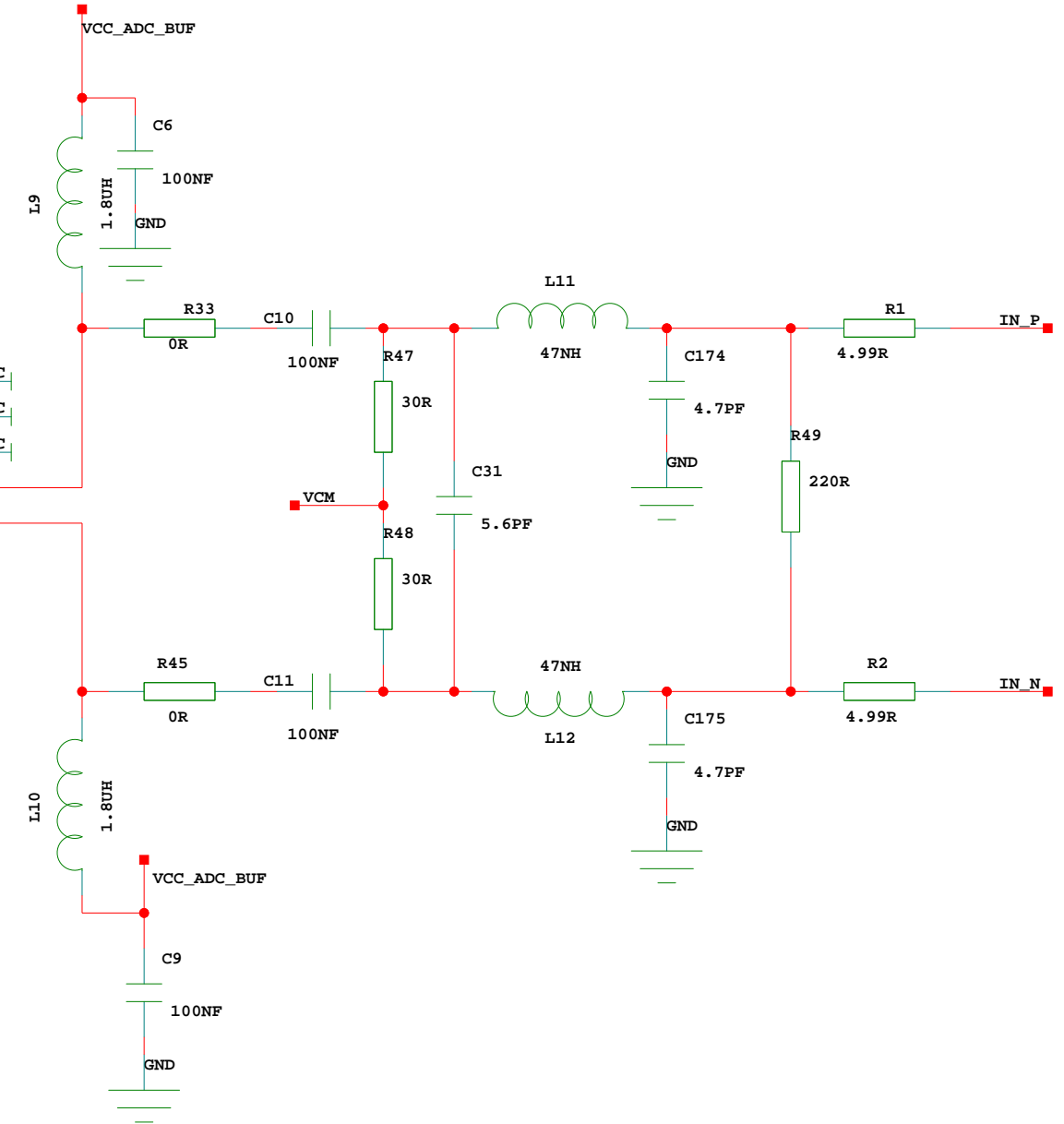

1 / 2

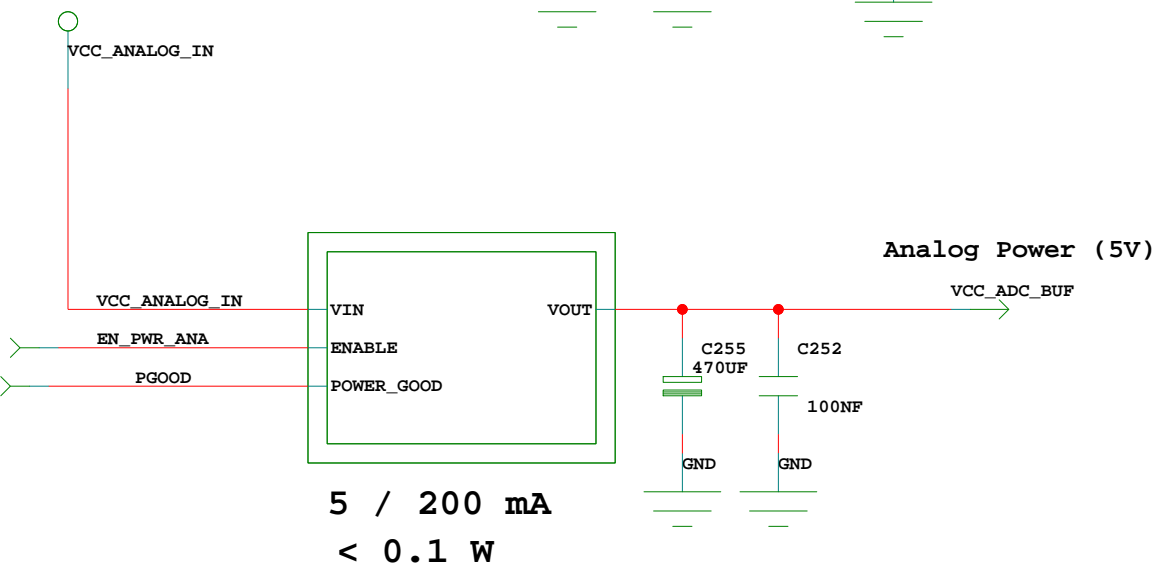

Analog Power (5V)

5 / 200 mA
< 0.1 W

ASTRON

Buffer Amplifier and ADC Ch

DESIGN		
Buffer Amplifier and ADC Ch		
SIZE	Filename	REV
A3		3.1
ADA4961_AD9683		
DRAWN BY	SHEET	DATE
Sieds / Gijs	5 of 76	08/04/2022:13:17

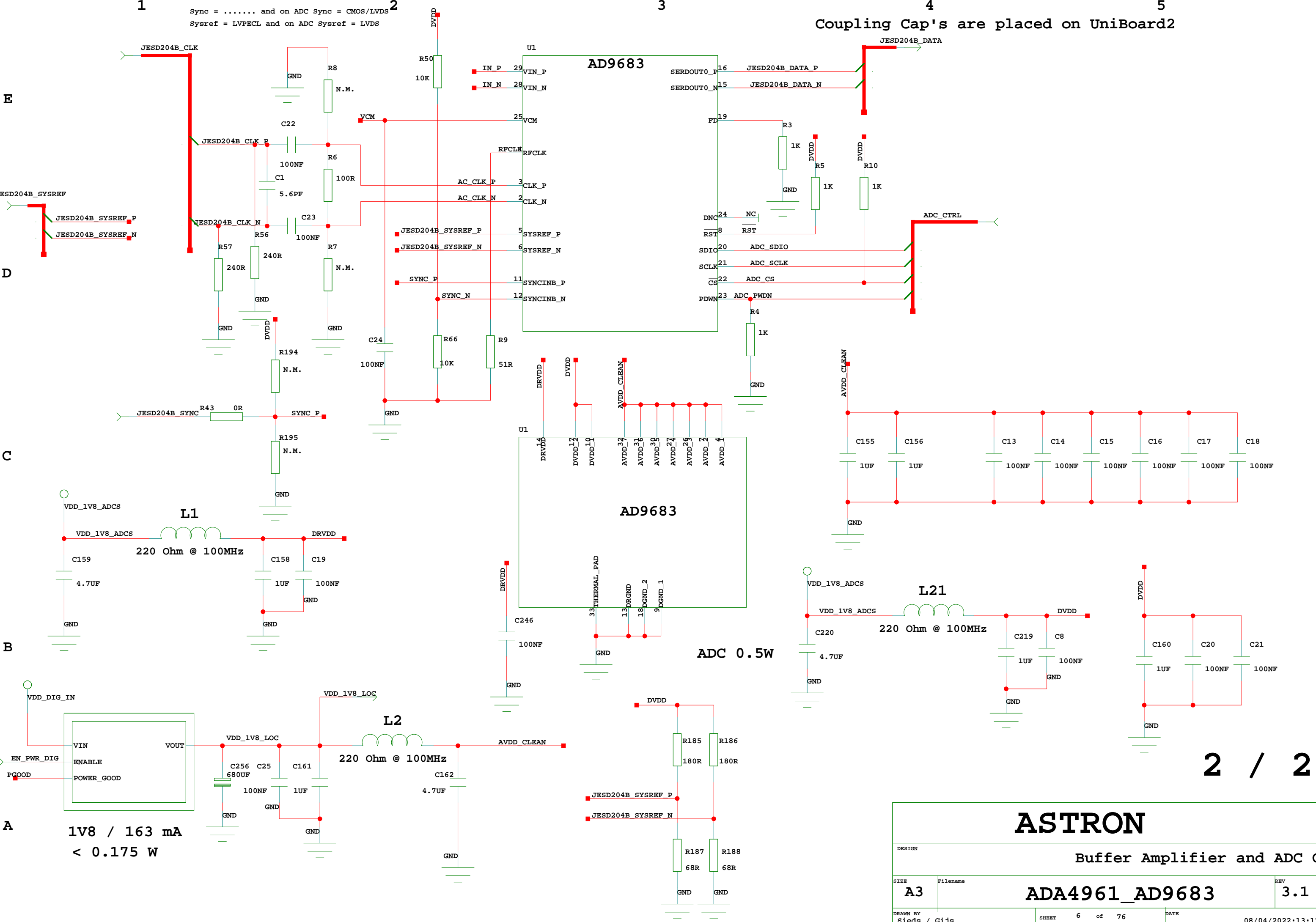

2 / 2

ASTRON		
DESIGN: Buffer Amplifier and ADC Ch		
SIZE: A3	Filename:	REV: 3.1
ADA4961_AD9683		
DRAWN BY: Sieds / Gijs	SHEET: 6 of 76	DATE: 08/04/2022:13:17

A
1V8 / 163 mA
< 0.175 W

ADC 0.5W

1

2

3

4

5

E

D

C

B

A

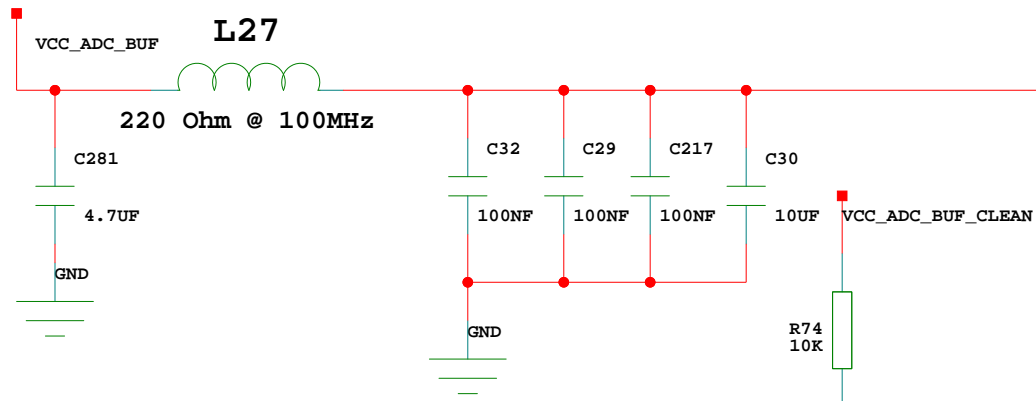

Decoupling of ADA, place close to the pins

Double Swap for layout

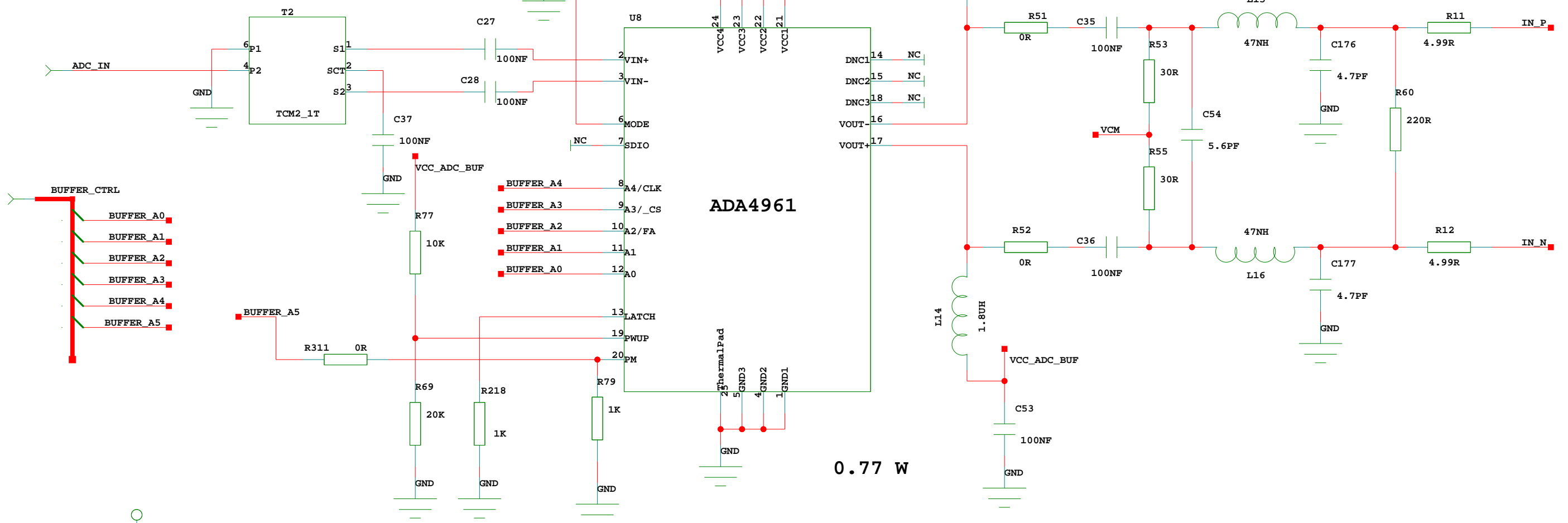

0.77 W

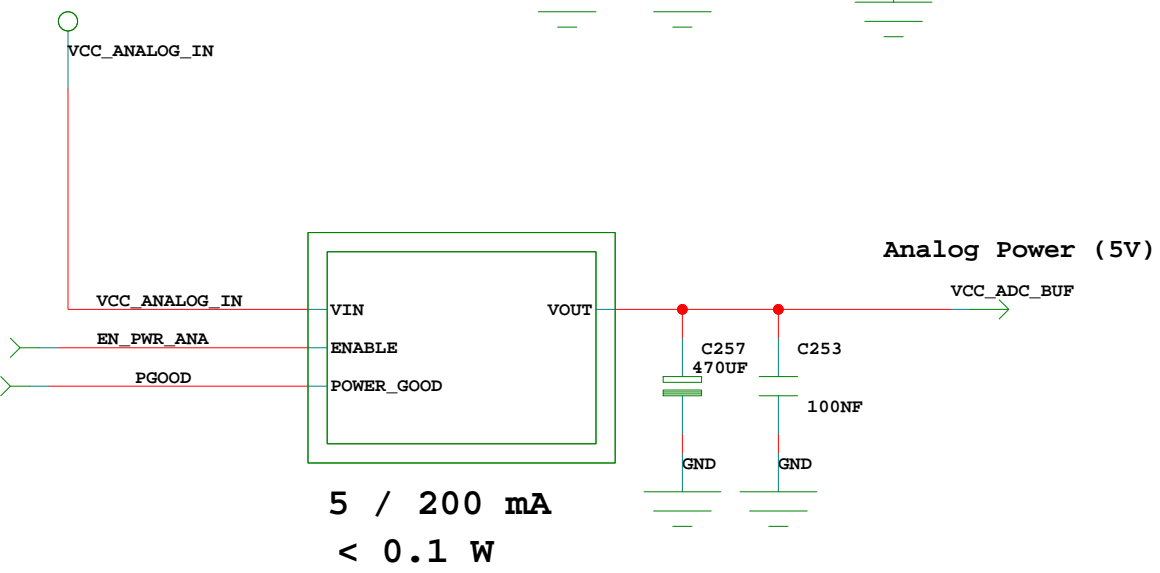

1 / 2

ASTRON

Buffer Amplifier and ADC Ch

DESIGN		
Buffer Amplifier and ADC Ch		
SIZE	Filename	REV
A3		3.1
DRAWN BY Sieds / Gijs		DATE
SHEET 7 of 76		08/04/2022:13:17

ADA4961_AD9683

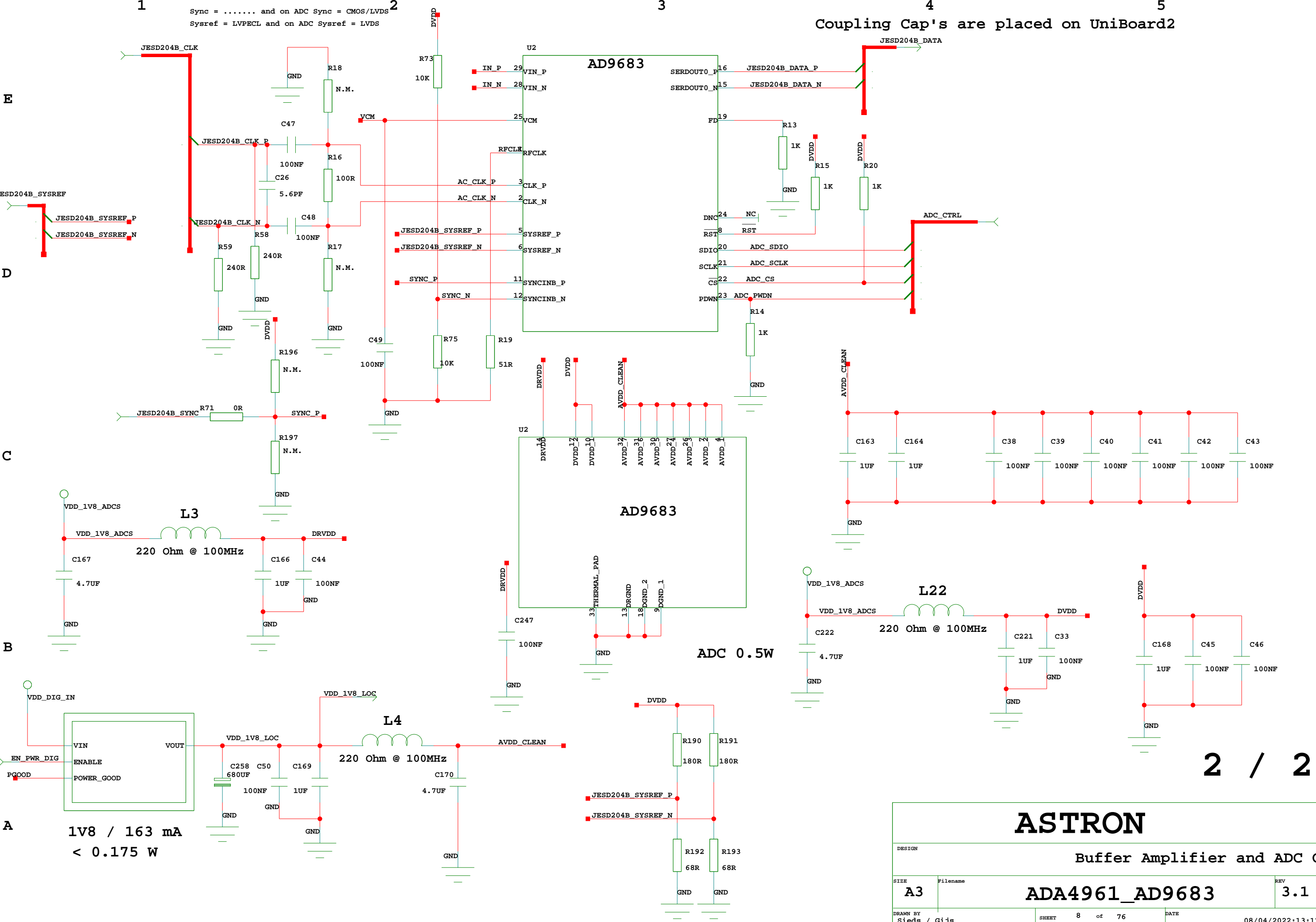

1

Sync = and on ADC Sync = CMOS/LVDS
 Sysref = LVPECL and on ADC Sysref = LVDS

E

D

C

B

A

3

4

5

Coupling Cap's are placed on UniBoard2

AD9683

AD9683

ADC 0.5W

1V8 / 163 mA
 < 0.175 W

2 / 2

ASTRON

Buffer Amplifier and ADC Ch

DESIGN		Buffer Amplifier and ADC Ch	
SIZE	Filename	REV	3.1
A3		ADA4961_AD9683	
DRAWN BY	Sheets / Gijs	SHEET	8 of 76
		DATE	08/04/2022:13:17

1

2

3

4

5

E

D

C

B

A

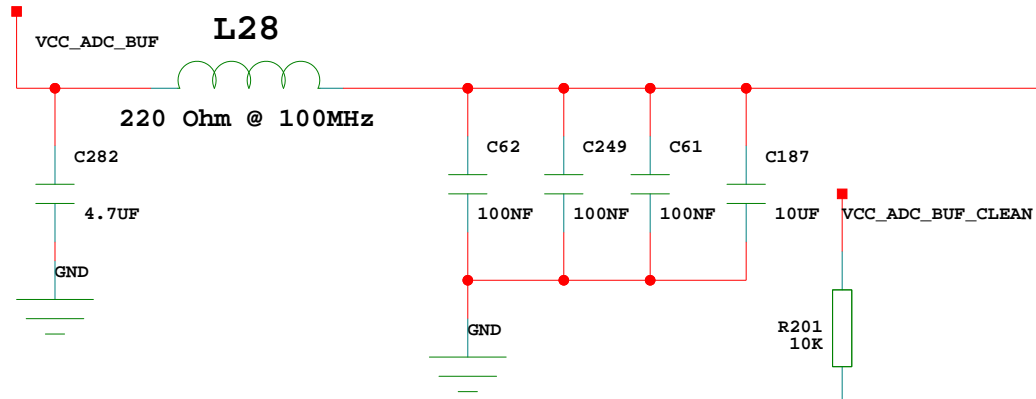

Decoupling of ADA, place close to the pins

Double Swap for layout

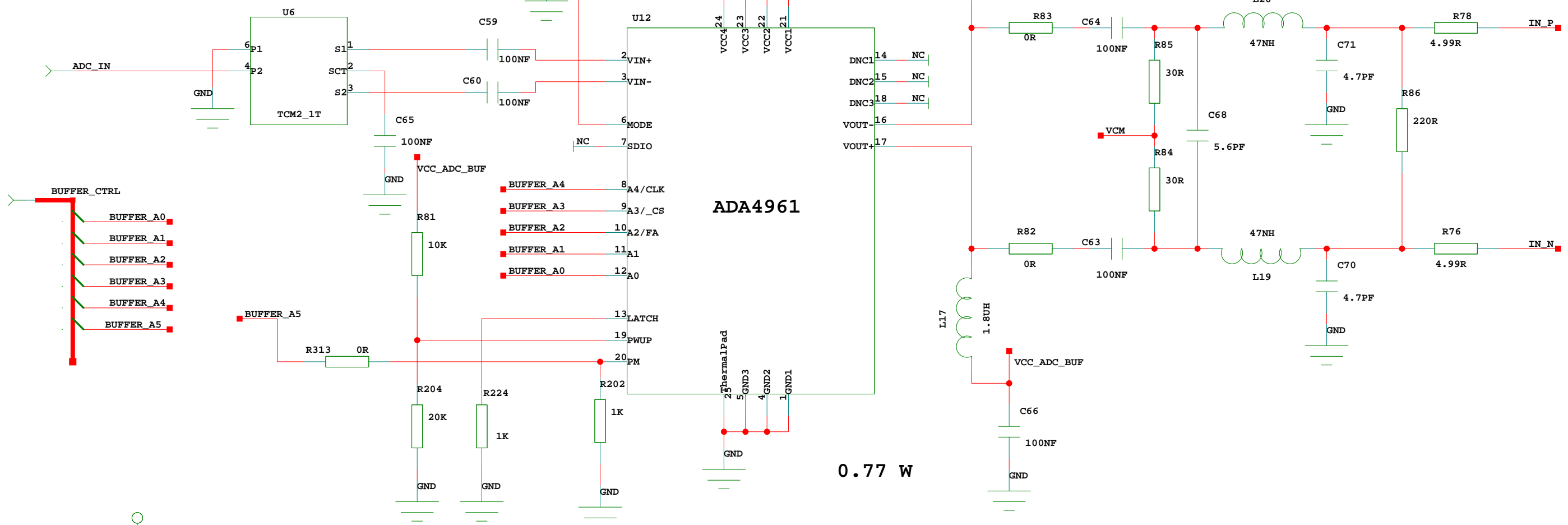

0.77 W

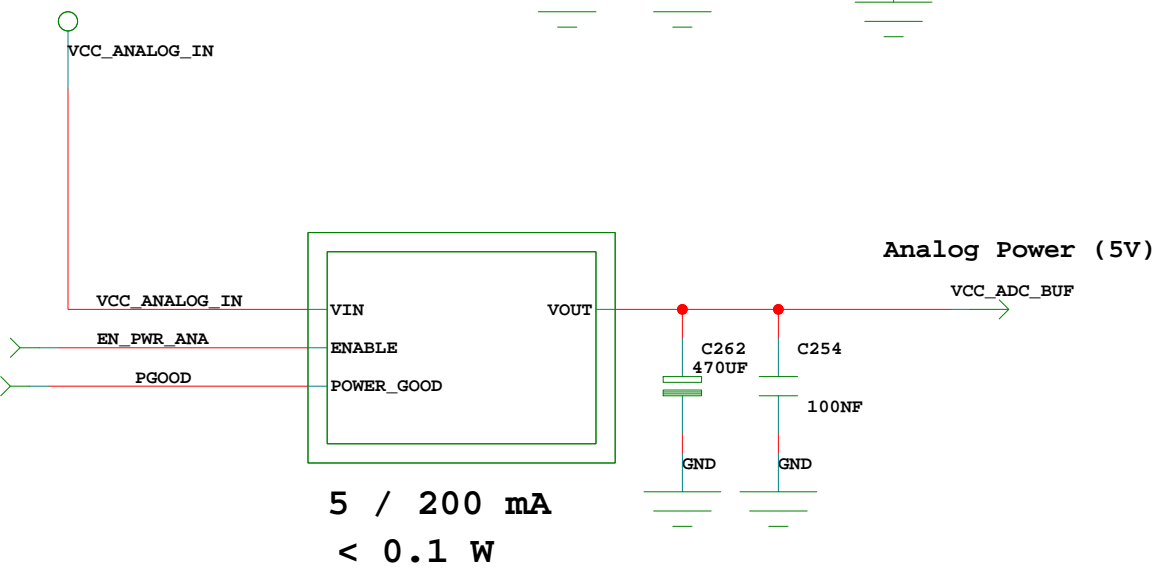

1 / 2

ASTRON

Buffer Amplifier and ADC Ch

DESIGN	Buffer Amplifier and ADC Ch	
SIZE	Filename	REV
A3	ADA4961_AD9683	3.1
DRAWN BY	SHEET	DATE
Sieds / Gijs	9 of 76	08/04/2022:13:17

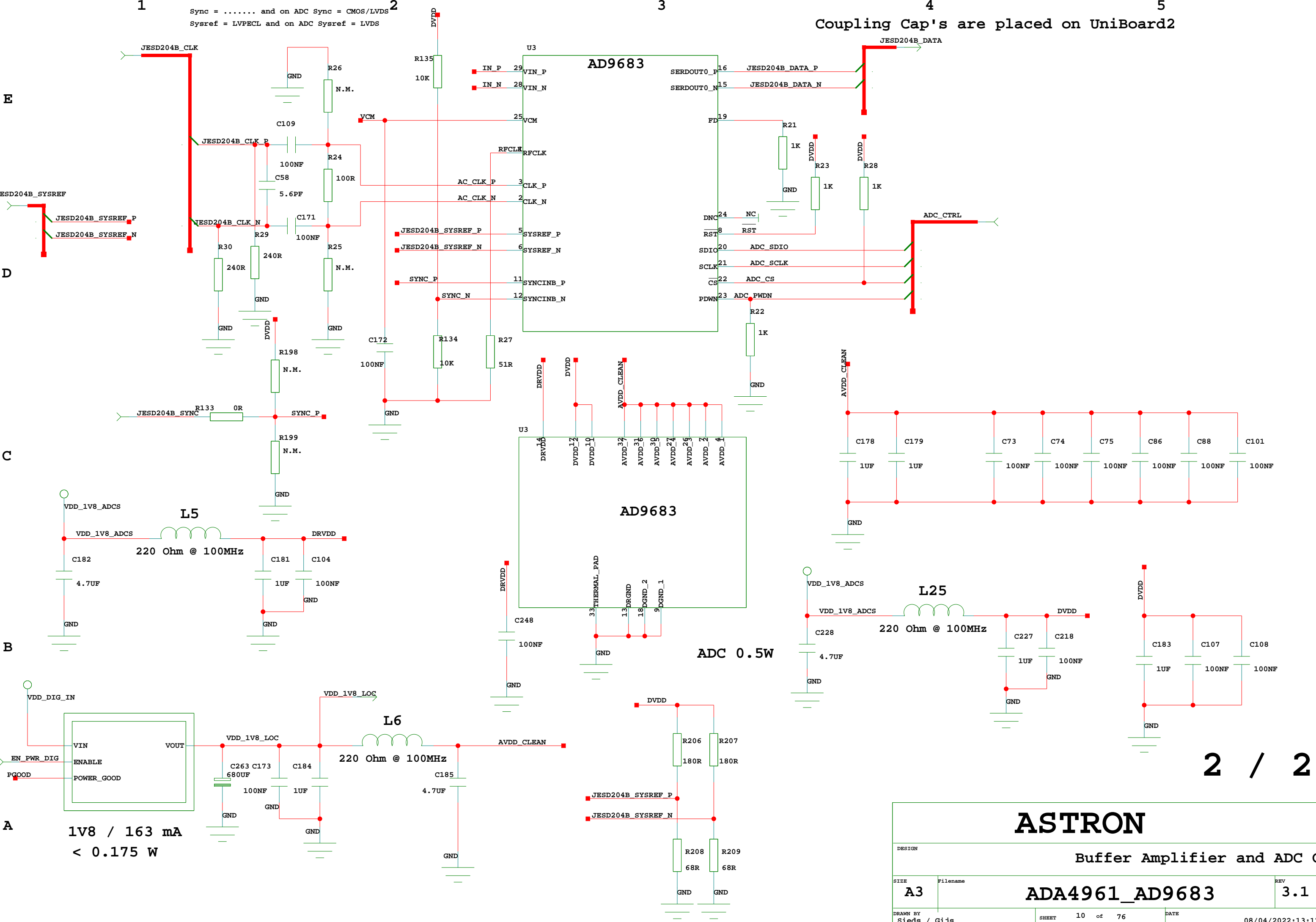

2 / 2

ASTRON

Buffer Amplifier and ADC Ch

DESIGN	ADA4961_AD9683		REV	3.1
SIZE	A3	Filename		
DRAWN BY	Sieds / Gijs		SHEET	10 of 76
			DATE	08/04/2022:13:17

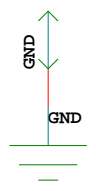
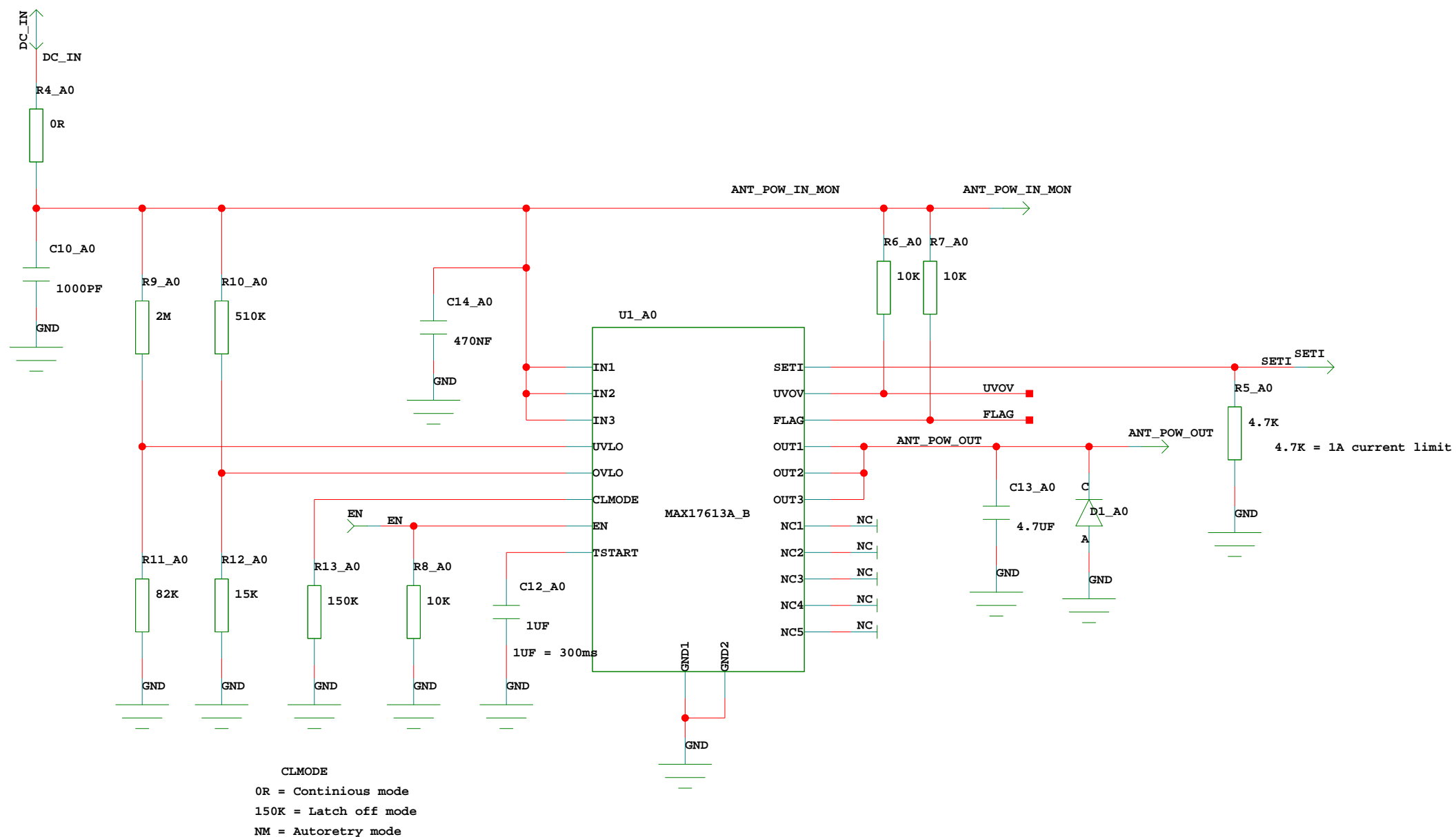

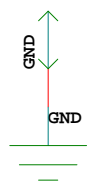
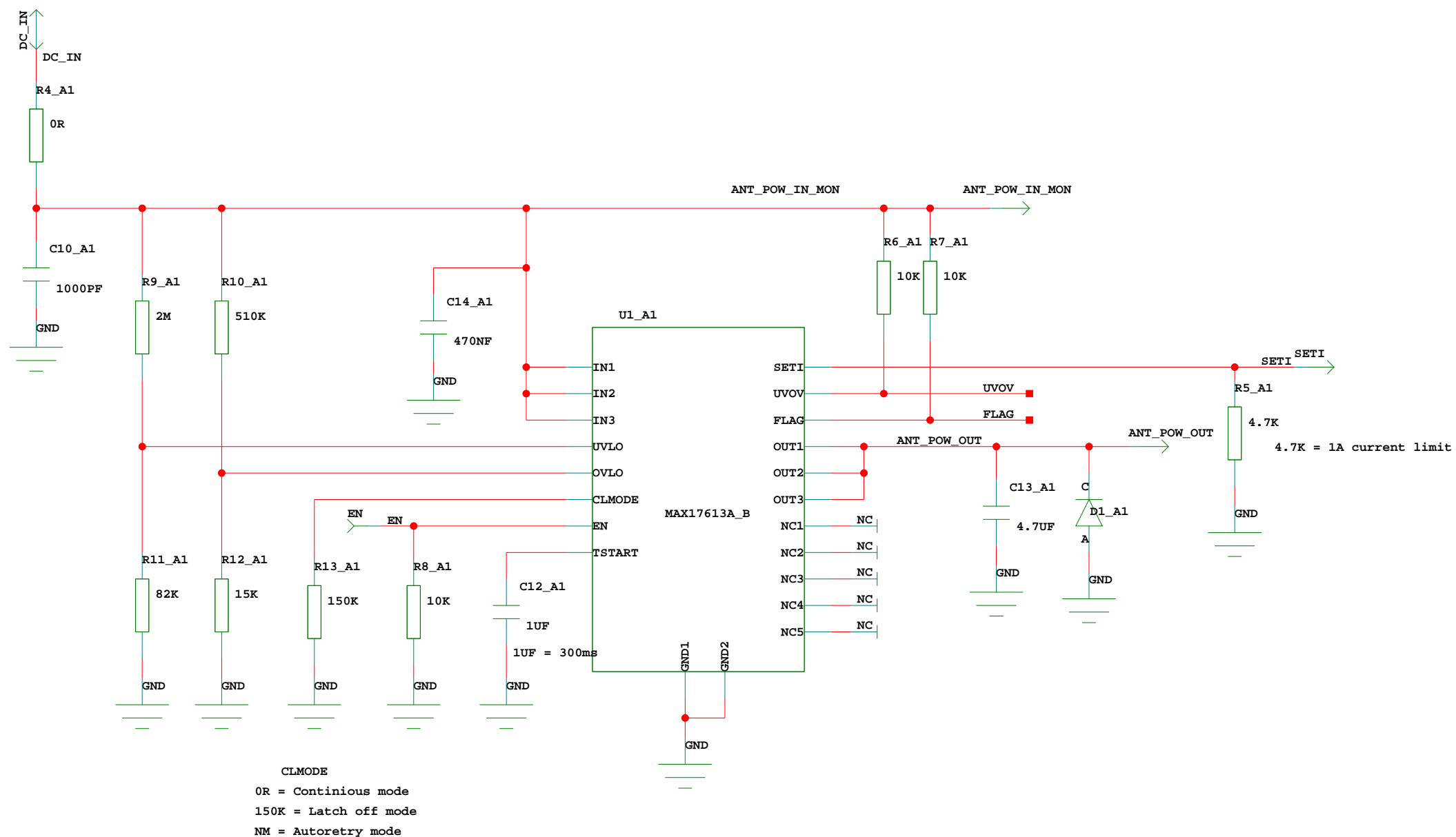

..

 ASTRON POSTBUS 2 DWINGELOO	DOC.NR.		
	Title ANTENNA POWER SWITCH HIGH BAND RCU2.0 LOFAR 2.0		
Drawn: S.Damstra	Size: A	Filename: Ant_Pow_Switch_HB_RCU2_0_LOFAR2_0	Project: LOFAR 2.0
Chk.: G.W.Schoonderbeek / P.Kruger	Date: 08/04/2022:13:17	Sheet: of 76	REV: 1.0

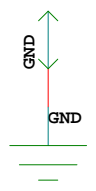
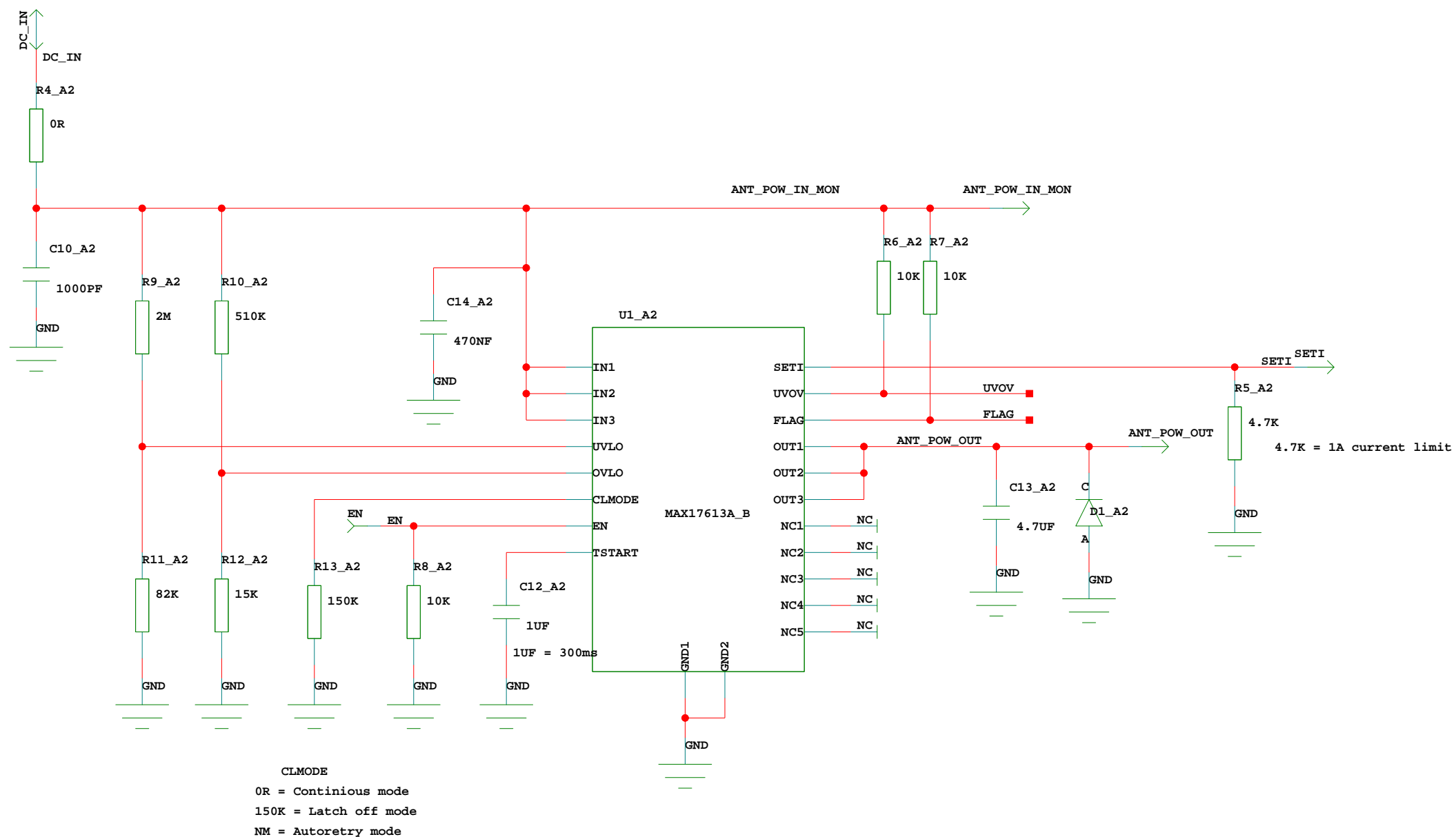

 ASTRON POSTBUS 2 DWINGELOO	DOC.NR.		
	Title ANTENNA POWER SWITCH HIGH BAND RCU2.0 LO		
Drawn: S.Damstra	Size: A	Filename: Ant_Pow_Switch_HB_RCU2_0_LOFAR2_0	Project: LOFAR 2.0
Chk.: G.W.Schoonderbeek / P.Kruger	Date: 08/04/2022:13:17	Sheet	of 76



 ASTRON POSTBUS 2 DWINGELOO	DOC.NR.		
	Title ANTENNA POWER SWITCH HIGH BAND RCU2.0 LO		
Drawn: S.Damstra	Size: A	Filename: Ant_Pow_Switch_HB_RCU2_0_LOFAR2_0	Project: LOFAR 2.0
Chk.: G.W.Schoonderbeek / P.Kruger	Date: 08/04/2022:13:17	Sheet	of 76

1

2

3

4

5

E

D

C

B

A

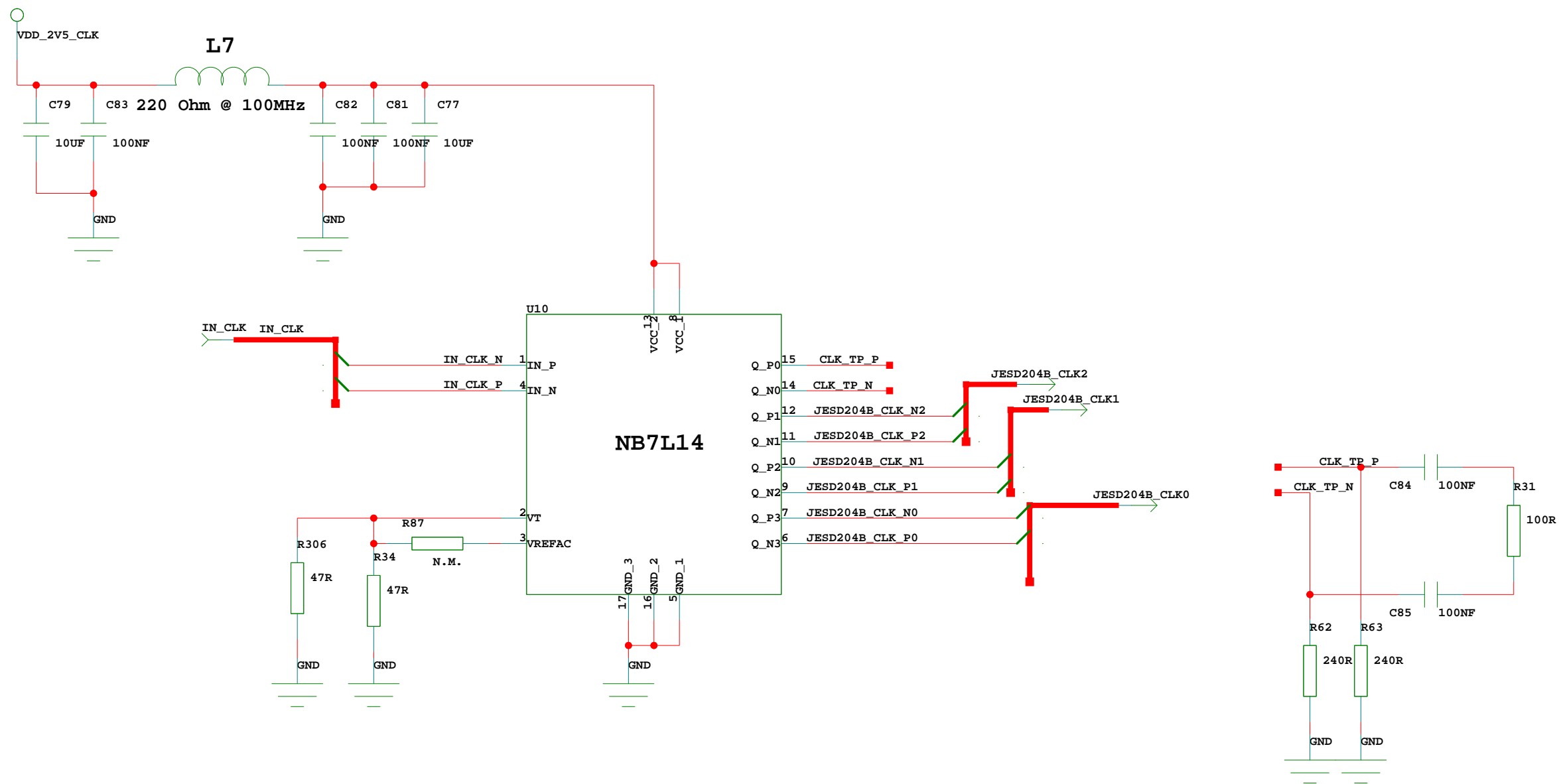

ASTRON

DESIGN		Clock Distribution Buffer	
SIZE	Filename	REV	
A3		CLK_DIST	3.1
DRAWN BY	SHEET	DATE	
Sieds / Gijs	15 of 76	08/04/2022:13:17	

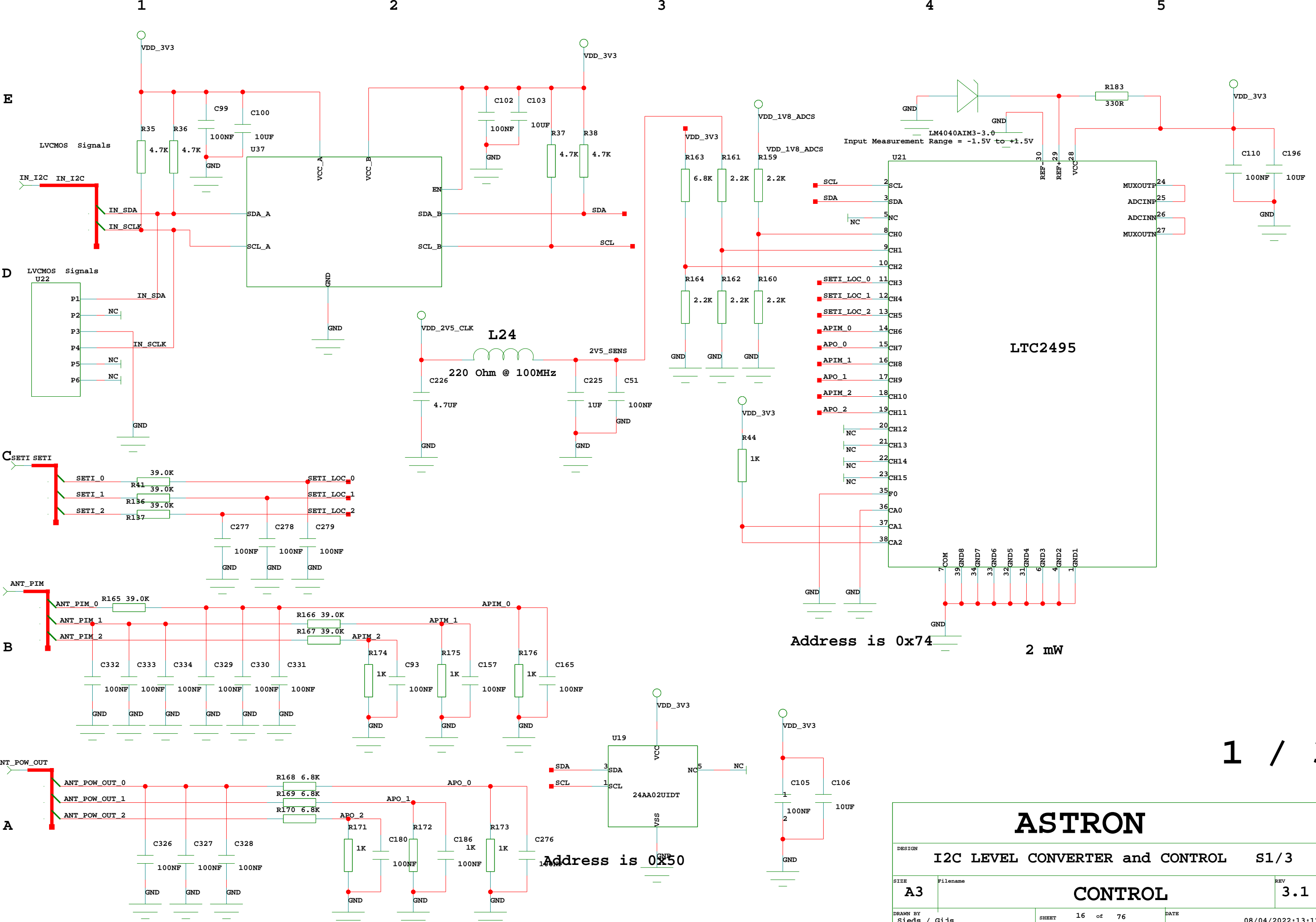

<h1>ASTRON</h1>		
DESIGN		S1 / 3
I2C LEVEL CONVERTER and CONTROL		
SIZE	Filename	REV
A3		3.1
DRAWN BY		DATE
Sieds / Gijs		08/04/2022:13:17
SHEET		REV
16 of 76		CONTROL

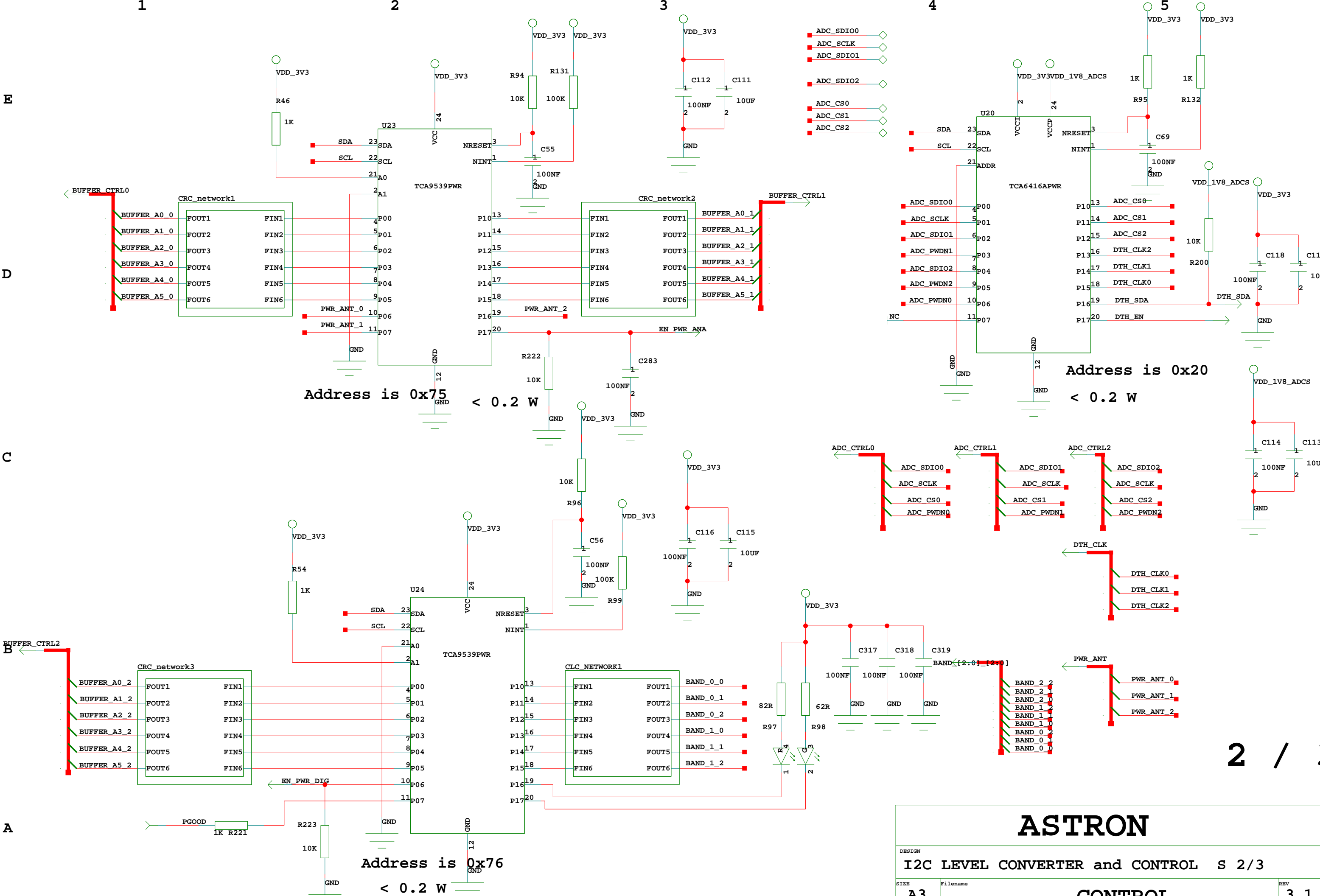

<h1>ASTRON</h1>		
DESIGN I2C LEVEL CONVERTER and CONTROL S 2/3		
SIZE A3	Filename	REV 3.1
DRAWN BY Sieds / Gijs		SHEET 17 of 76 DATE 08/04/2022:13:17

E

D

C

B

A

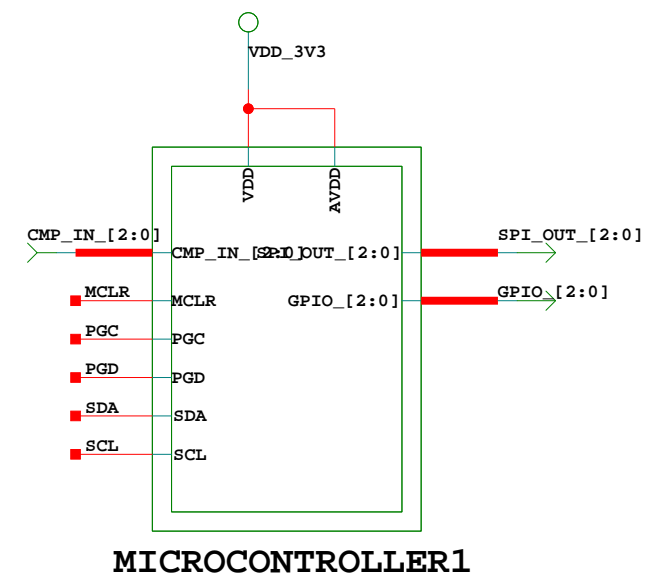
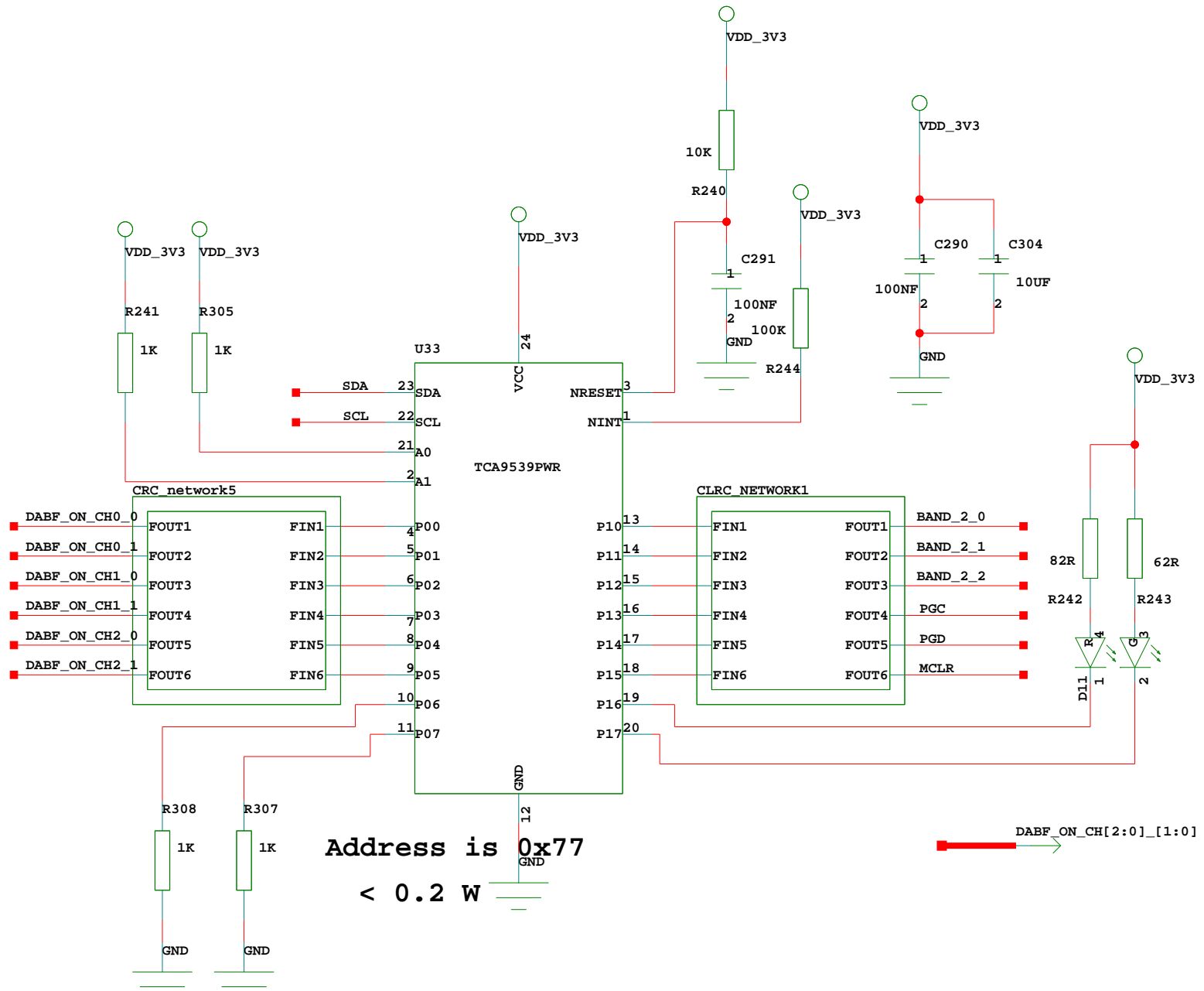

ASTRON

DESIGN			
I2C LEVEL CONVERTER and CONTROL S 3/3			
SIZE	Filename	REV	
A3		CONTROL 3.1	
DRAWN BY		SHEET	DATE
Sieds / Gijs		18 of 76	08/04/2022:13:17

Balun and Bandpass filter with Fc at 102 MHz

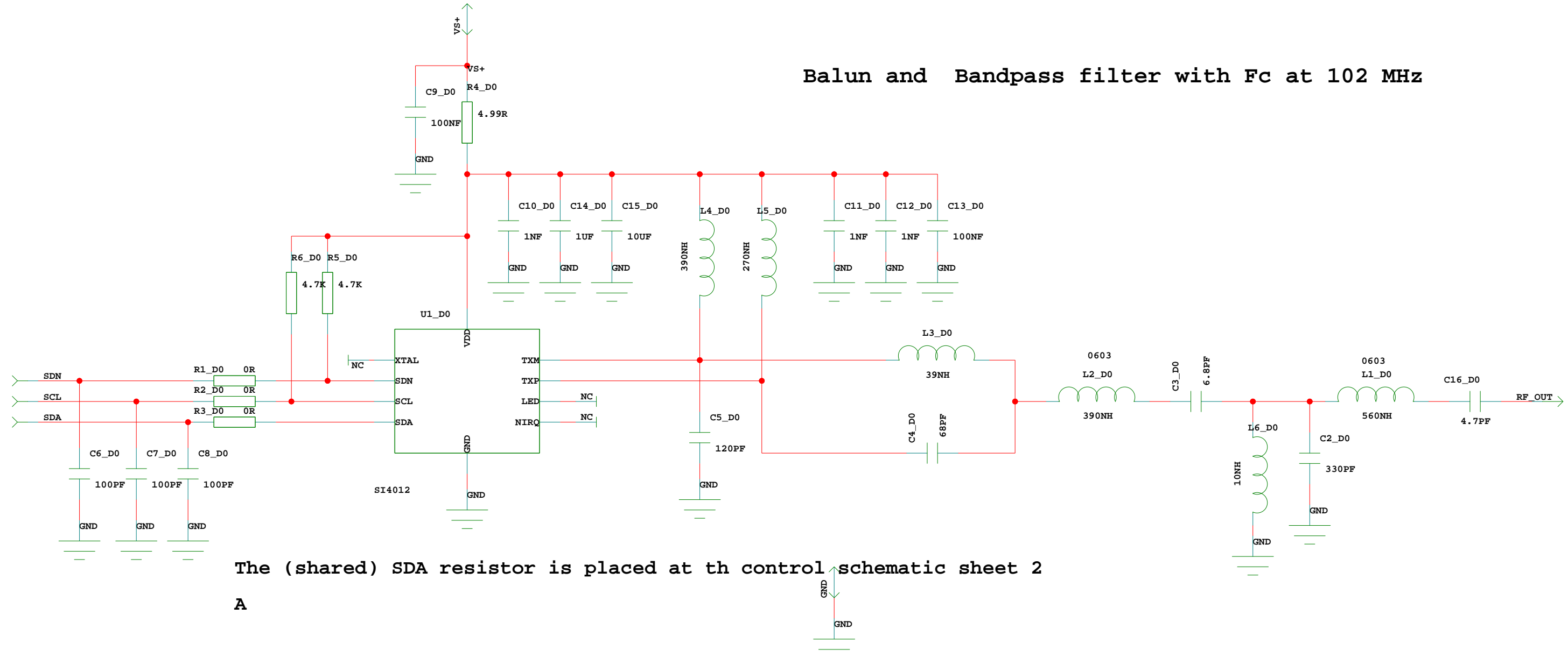

ASTRON
POSTBUS 2
DWINGELOO

DOC.NR.

Title

Dither RCU2.0 LOFAR 2.0

Drawn: S.Damstra

Size
A

Filename
Dither_HB_RCU2_0_LOFAR2_0

Project
LOFAR 2.0

REV
1.0

Chk.: G.W.Schoonderbeek / P.Kruger

Date: 08/04/2022:13:17

Sheet of 76

Balun and Bandpass filter with Fc at 102 MHz

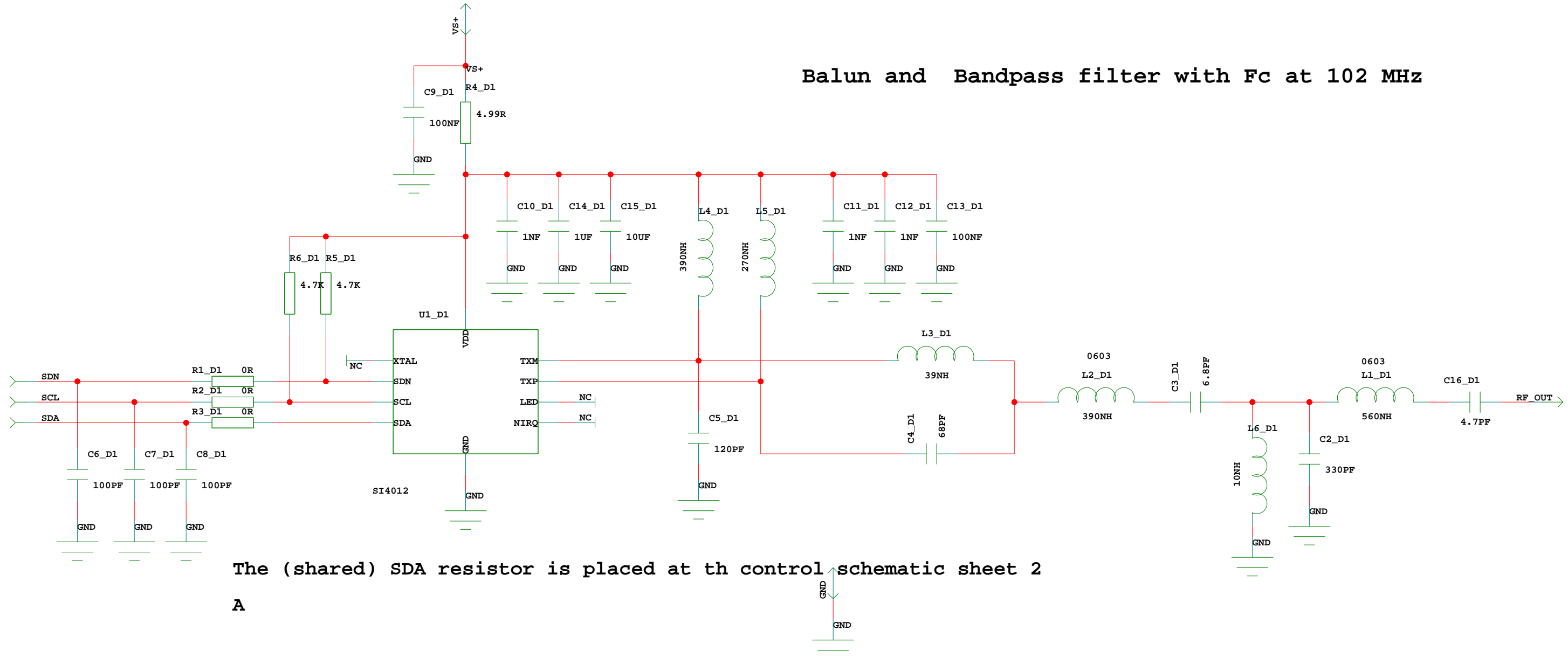

 ASTRON POSTBUS 2 DWINGELOO	DOC.NR.		
	Title Dither RCU2.0 LOFAR 2.0		
Drawn: S.Damstra	Size A	Filename Dither_HB_RCU2_0_LOFAR2_0	Project LOFAR 2.0
Chk.: G.W.Schoonderbeek / P.Kruger	Date: 08/04/2022:13:17	Sheet	REV 1.0

Balun and Bandpass filter with Fc at 102 MHz

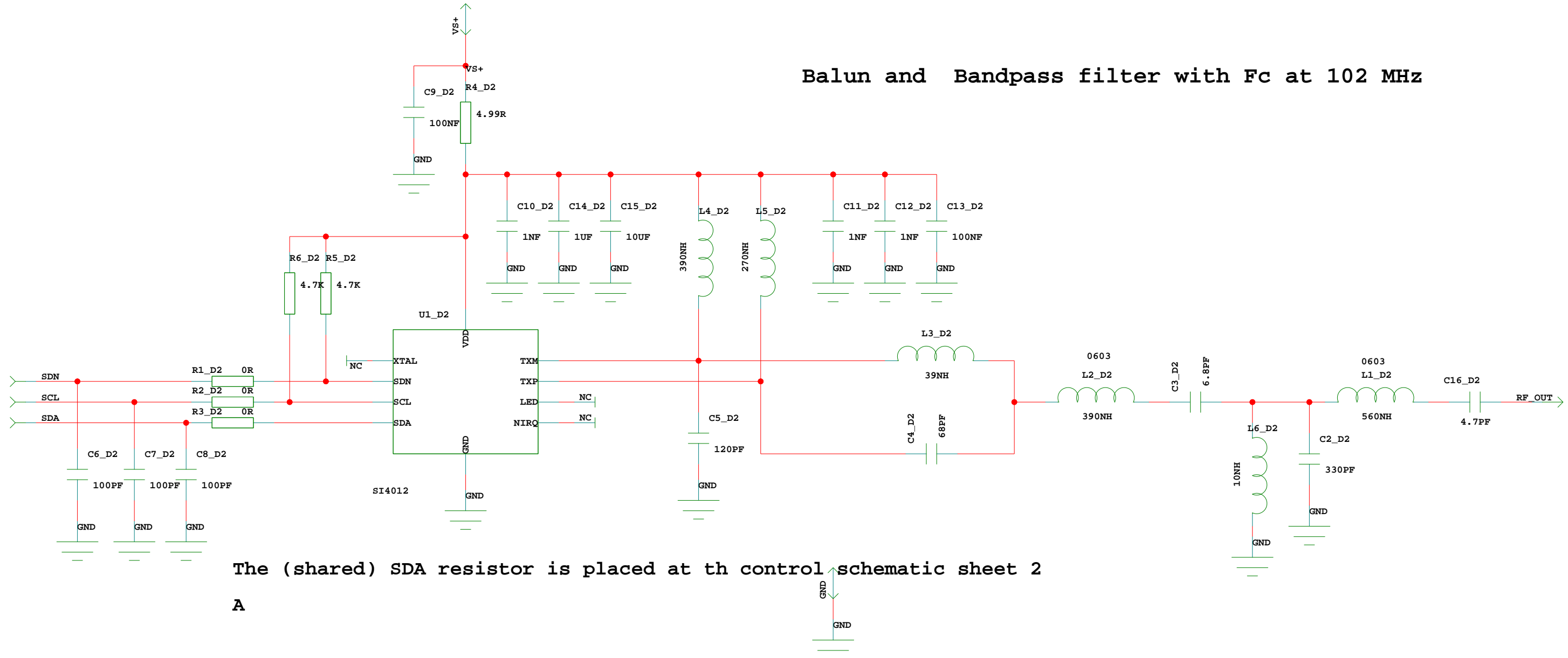

ASTRON
POSTBUS 2
DWINGELOO

DOC.NR.

Title

Dither RCU2.0 LOFAR 2.0

Drawn: S.Damstra

Size

A

Filename

Dither_HB_RCU2_0_LOFAR2_0

Project

LOFAR 2.0

REV

1.0

Chk.: G.W.Schoonderbeek / P.Kruger

Date:

08/04/2022:13:17

Sheet

of 76

1

2

3

4

5

E

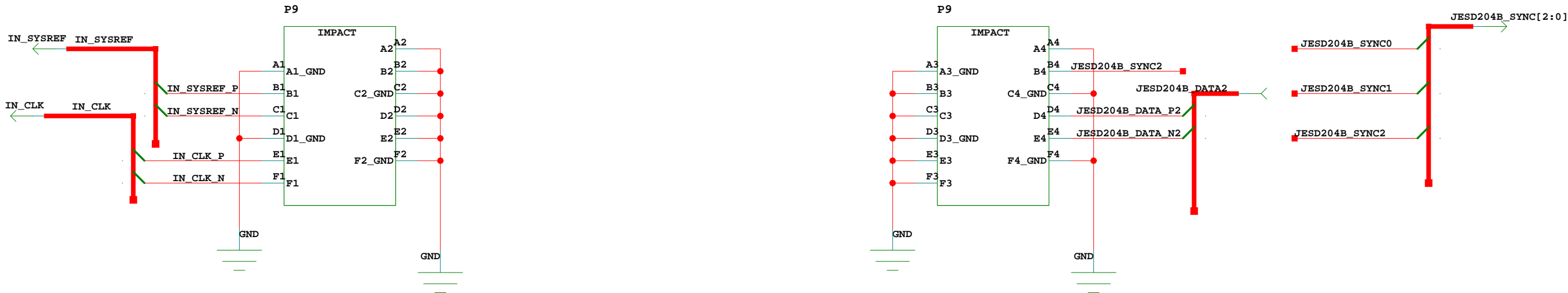

D

C

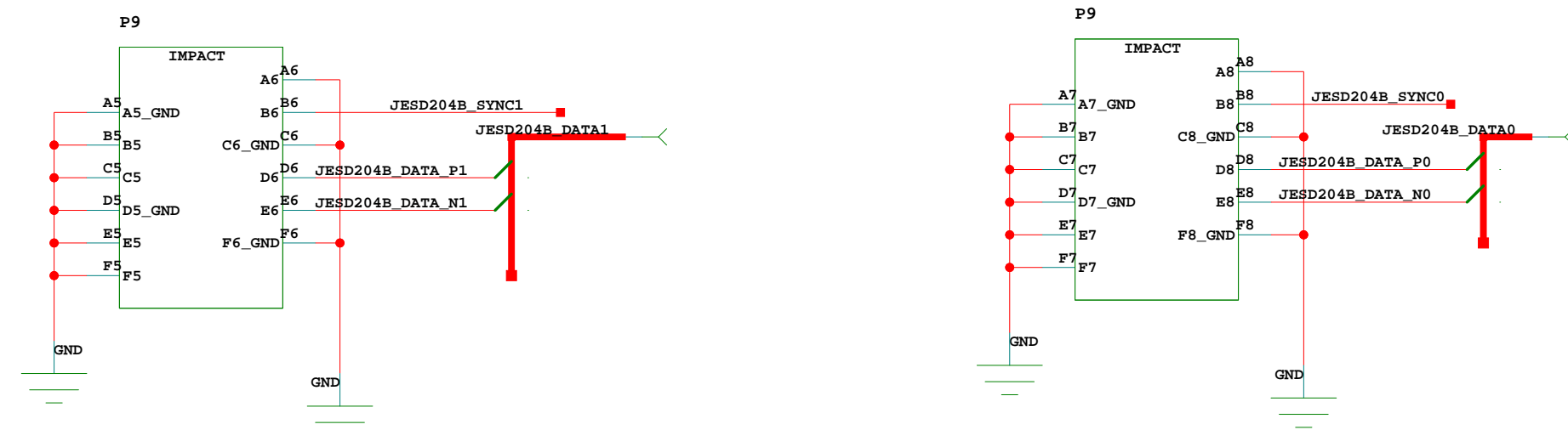

B

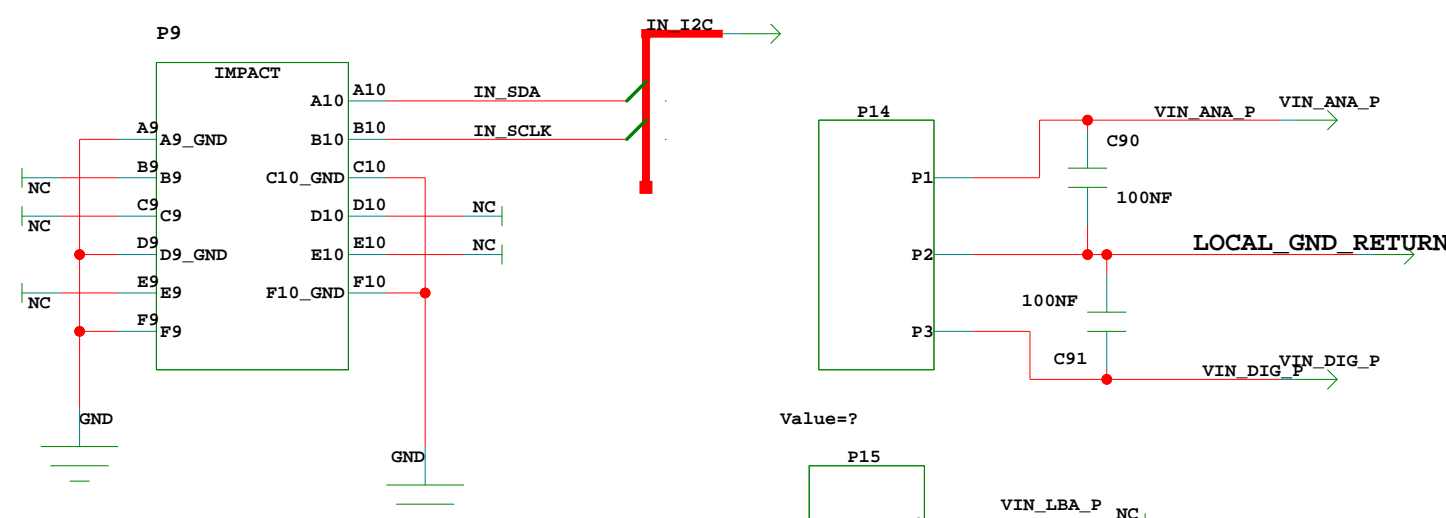

A

<h1>ASTRON</h1>			
DESIGN: Midplane connectors			
SIZE: A3	Filename:	<h2>LMP_CONNECT</h2>	
REV: 3.1	DRAWN BY: Sieds / Gijs	SHEET: 22 of 76	DATE: 08/04/2022:13:17

Analog Power Input

Control

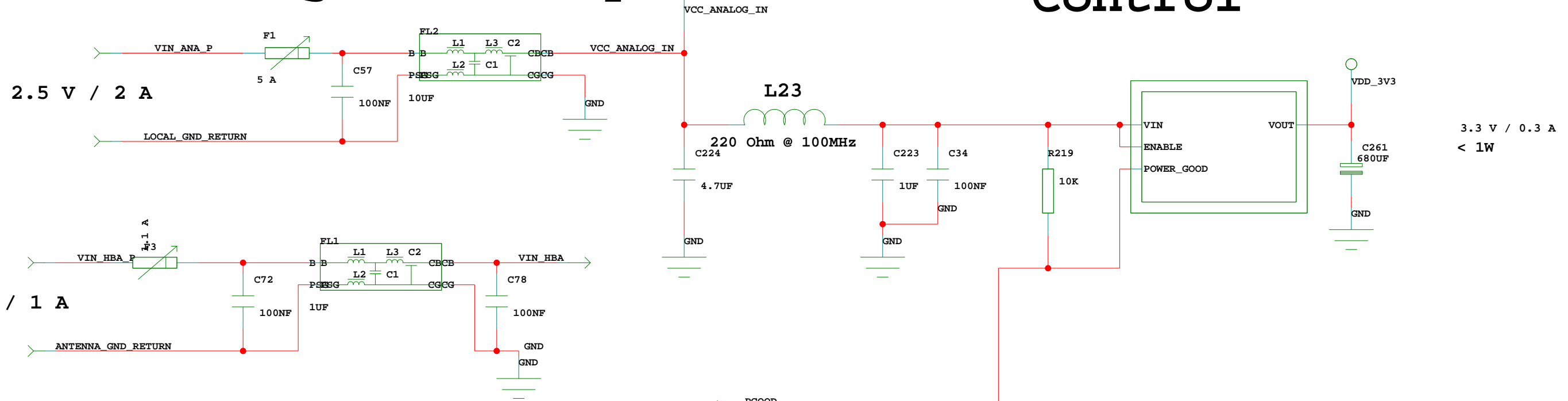

Digital Power Supplies

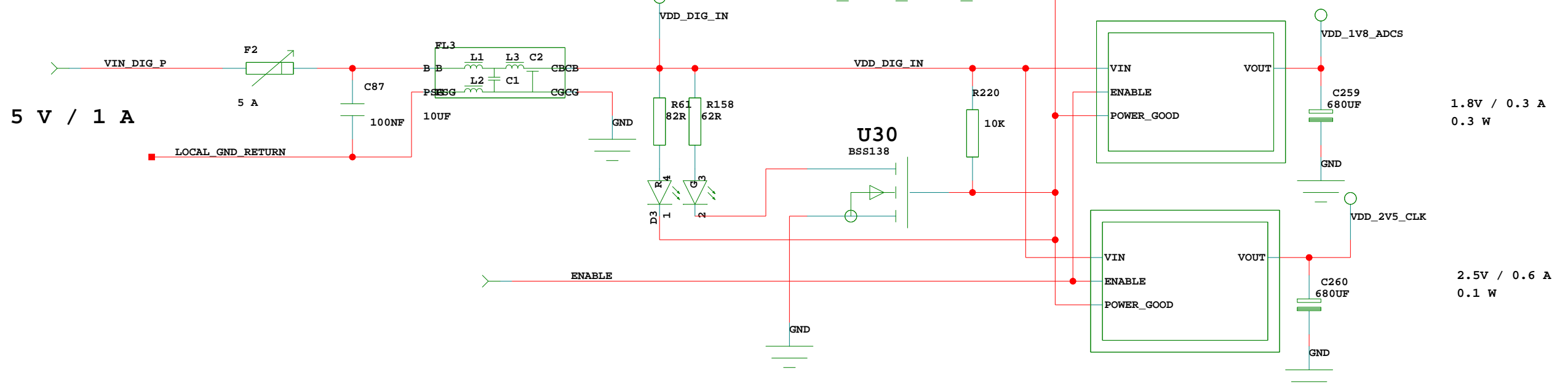

ASTRON

DESIGN		Digital Power Supplies	
SIZE	Filename	REV	
A3		POWER	3.1
DRAWN BY	SHEET	DATE	
Sieds / Gijs	23 of 76	08/04/2022:13:16	

1

2

3

4

5

E

D

C

B

A

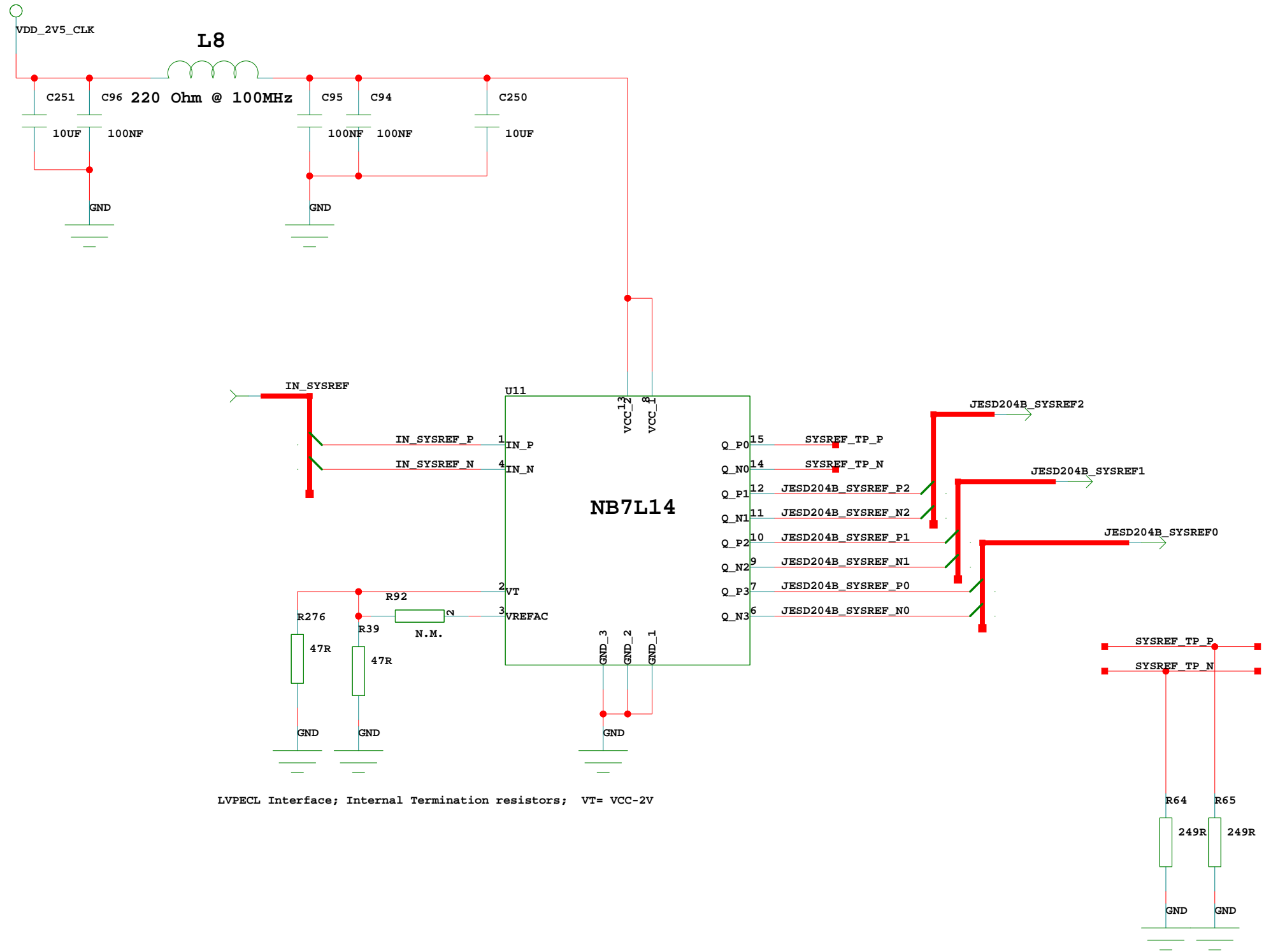

ASTRON

DESIGN SYSREF Distribution Buffer

SIZE A3	Filename	SYSREF_DIST	REV 3.1
-------------------	----------	--------------------	-------------------

DRAWN BY Sieds / Gijs	SHEET 24 of 76	DATE 08/04/2022:13:17
--------------------------	-------------------	--------------------------

1

2

3

4

5

F

D

C

B

A

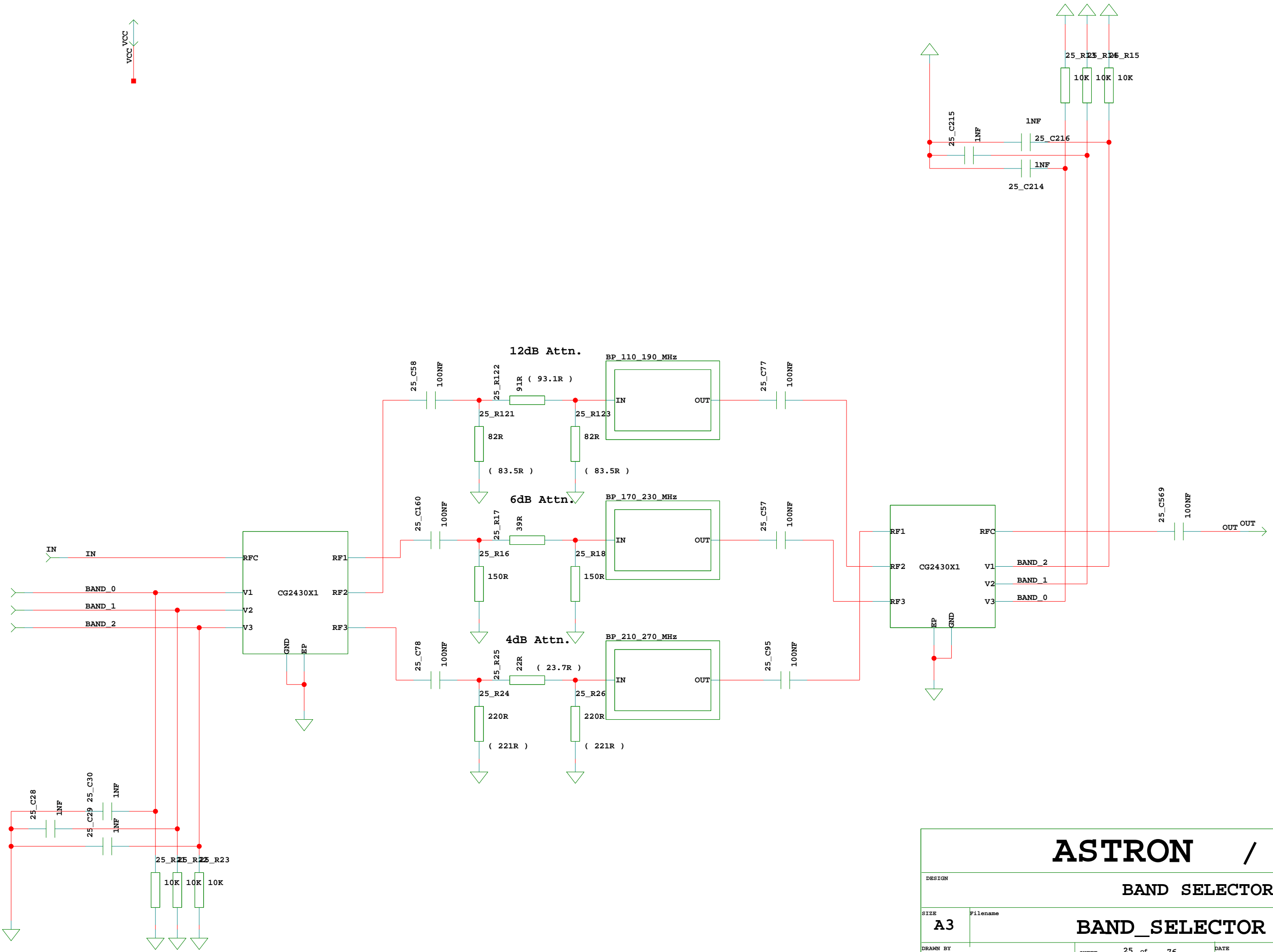

ASTRON / INAF			
DESIGN			
BAND SELECTOR CHO			
SIZE	Filename	REV	
A3		3.1	
DRAWN BY	SHEET	DATE	
Sieds / Gijs	25 of 76	08/04/2022:13:52	

1

2

3

4

5

F

D

C

B

A

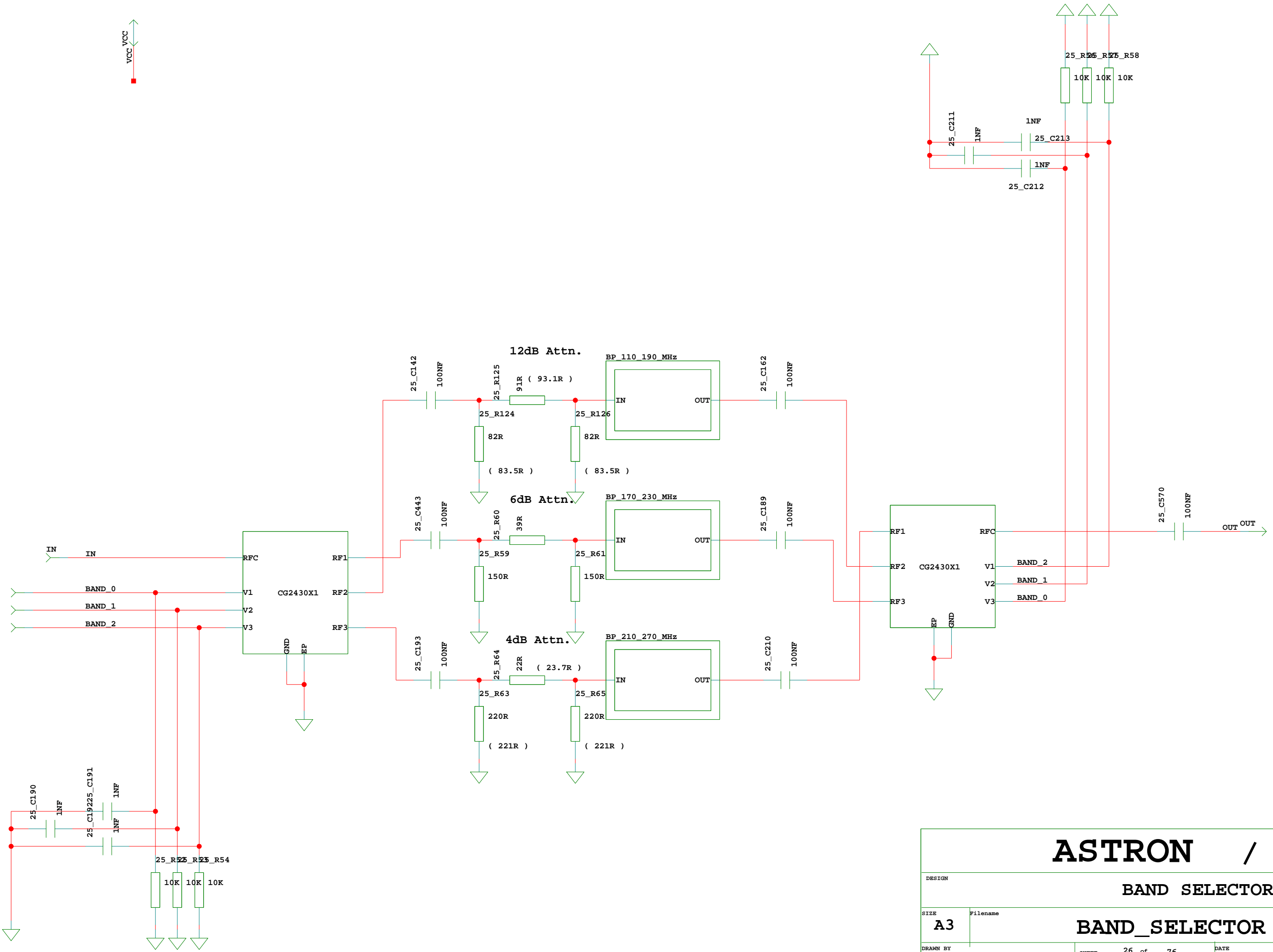

ASTRON / INAF			
DESIGN			
BAND SELECTOR CH1			
SIZE	Filename	REV	
A3		3.1	
DRAWN BY		SHEET	DATE
Sieds / Gijs		26 of 76	08/04/2022:13:52

1

2

3

4

5

F

D

C

B

A

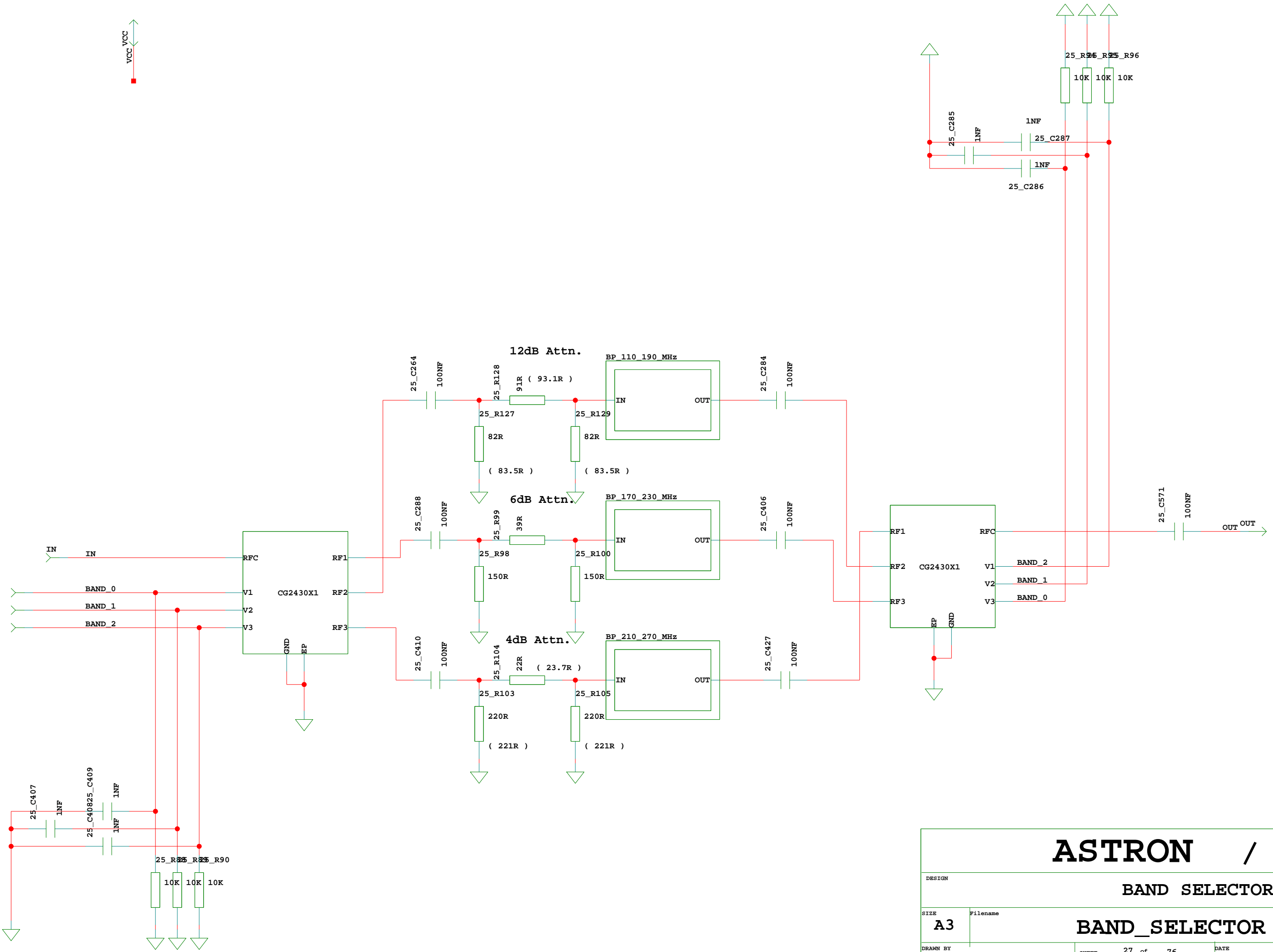

ASTRON / INAF			
DESIGN			
BAND_SELECTOR CH2			
SIZE	Filename	REV	
A3		3.1	
DRAWN BY	SHEET	DATE	
Sieds / Gijs	27 of 76	08/04/2022:13:52	

1

2

3

4

5

E

D

C

B

A

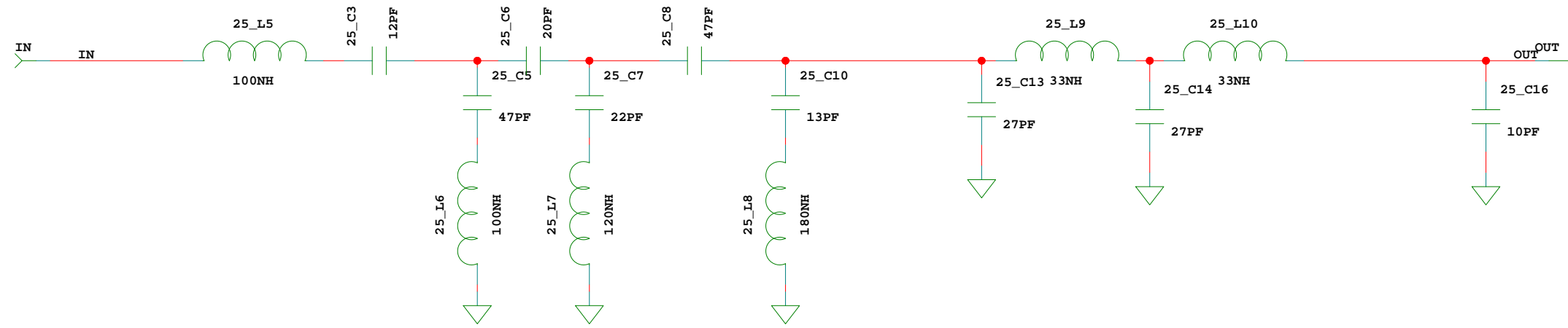

ASTRON / INAF

DESIGN		BP 110 - 290 MHz CH0	
SIZE	Filename	REV	
A3	BP_110_290_MHz	3.1	
DRAWN BY Sieds / Gijs		SHEET 28 of 76	DATE 08/04/2022:13:17

1

2

3

4

5

E

D

C

B

A

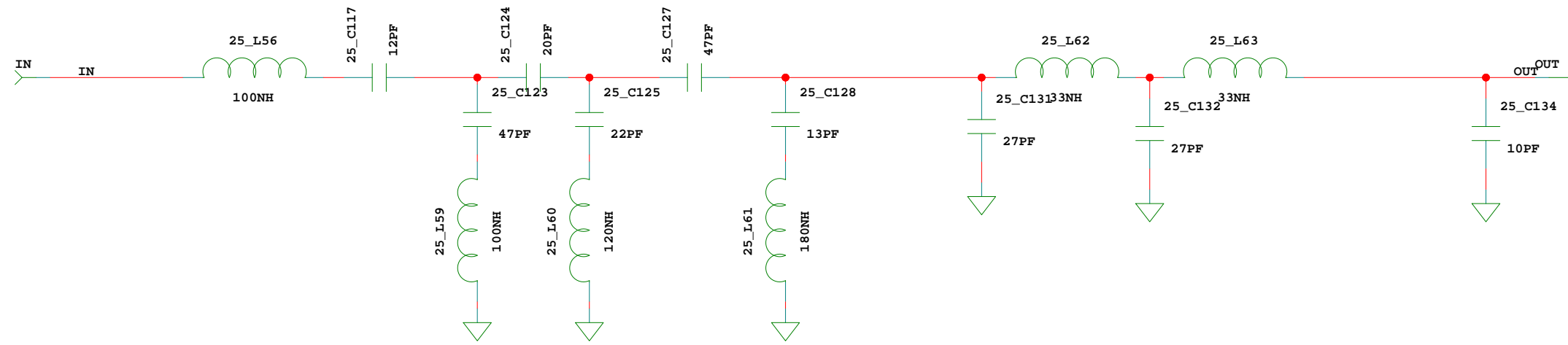

ASTRON / INAF			
DESIGN BP 110 - 290 MHz CH1			
SIZE A3	Filename BP_110_290_MHz	REV 3.1	
DRAWN BY Sieds / Gijs		SHEET 29 of 76	DATE 08/04/2022:13:17

1

2

3

4

5

E

D

C

B

A

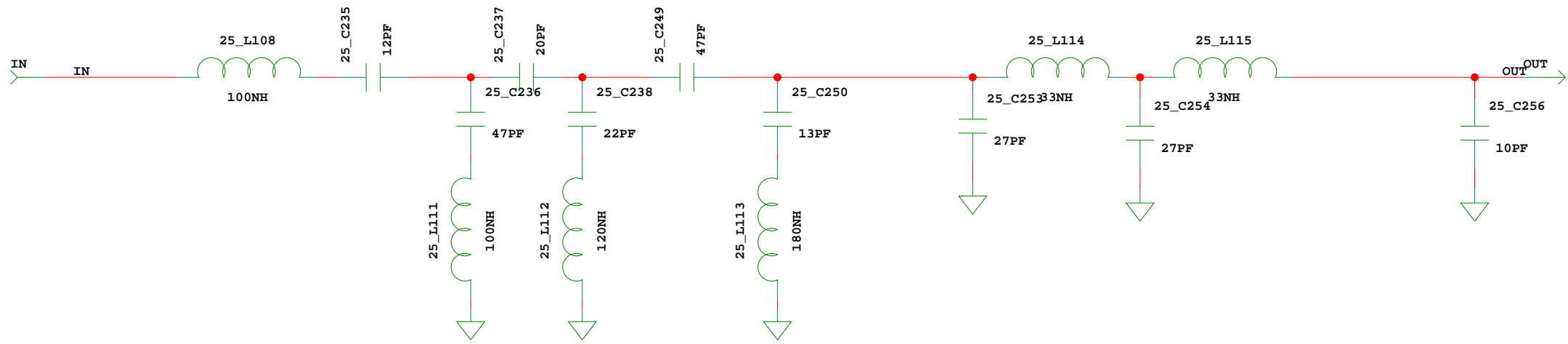

ASTRON / INAF

DESIGN		BP 110 - 290 MHz CH2	
SIZE	Filename	REV	
A3	BP_110_290_MHz	3.1	
DRAWN BY Sieds / Gijs		SHEET 30 of 76	DATE 08/04/2022:13:17

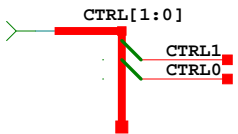
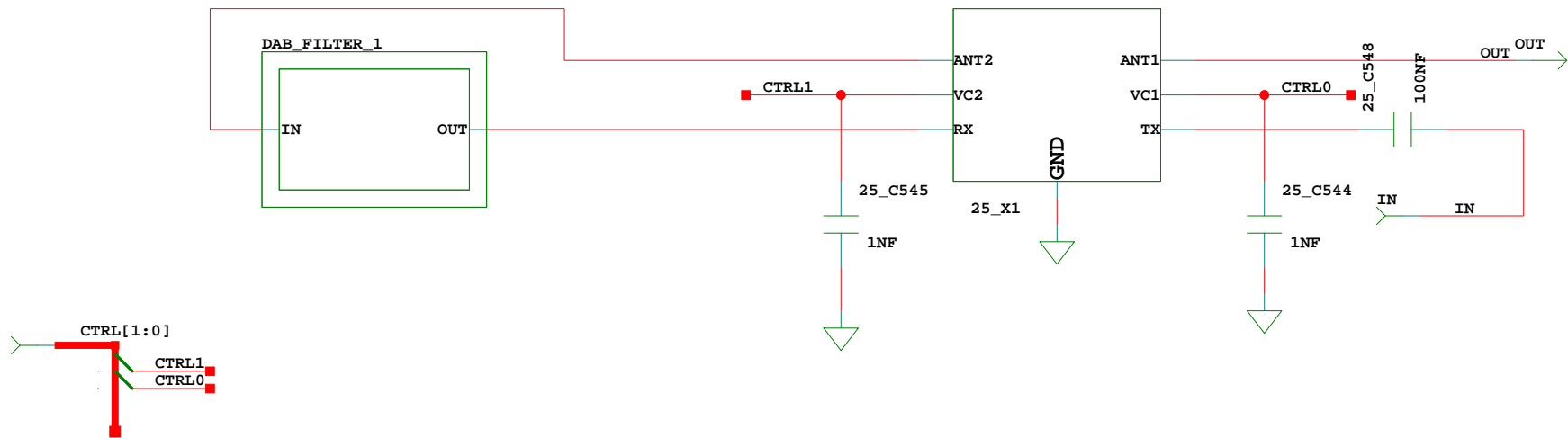

ASTRON / INAF			
DESIGN		DAB_FILTER_ON_OFF CH0	
SIZE	Filename	DAB_FILTER_ON_OFF	REV
A1			3.1
DRAWN BY Sieds / Gijs		SHEET 31 of 76	DATE 08/04/2022:13:17

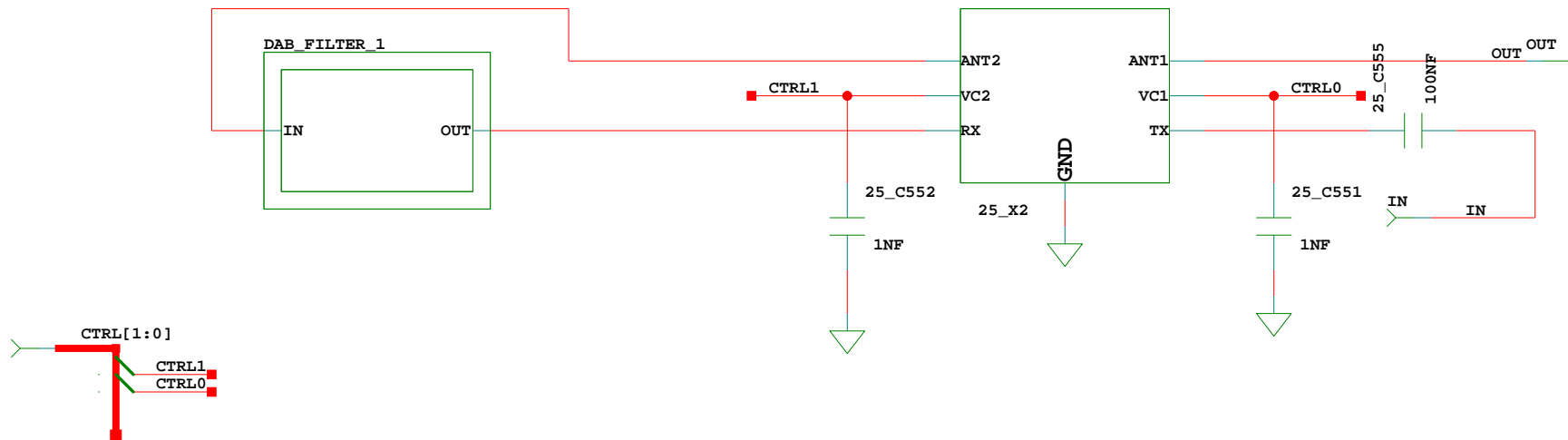

ASTRON / INAF

DESIGN

DAB_FILTER_ON_OFF CH1

SIZE

A1

Filename

DAB_FILTER_ON_OFF

REV

3.1

DRAWN BY

Sieds / Gijs

SHEET

32 of 76

DATE

08/04/2022:13:17

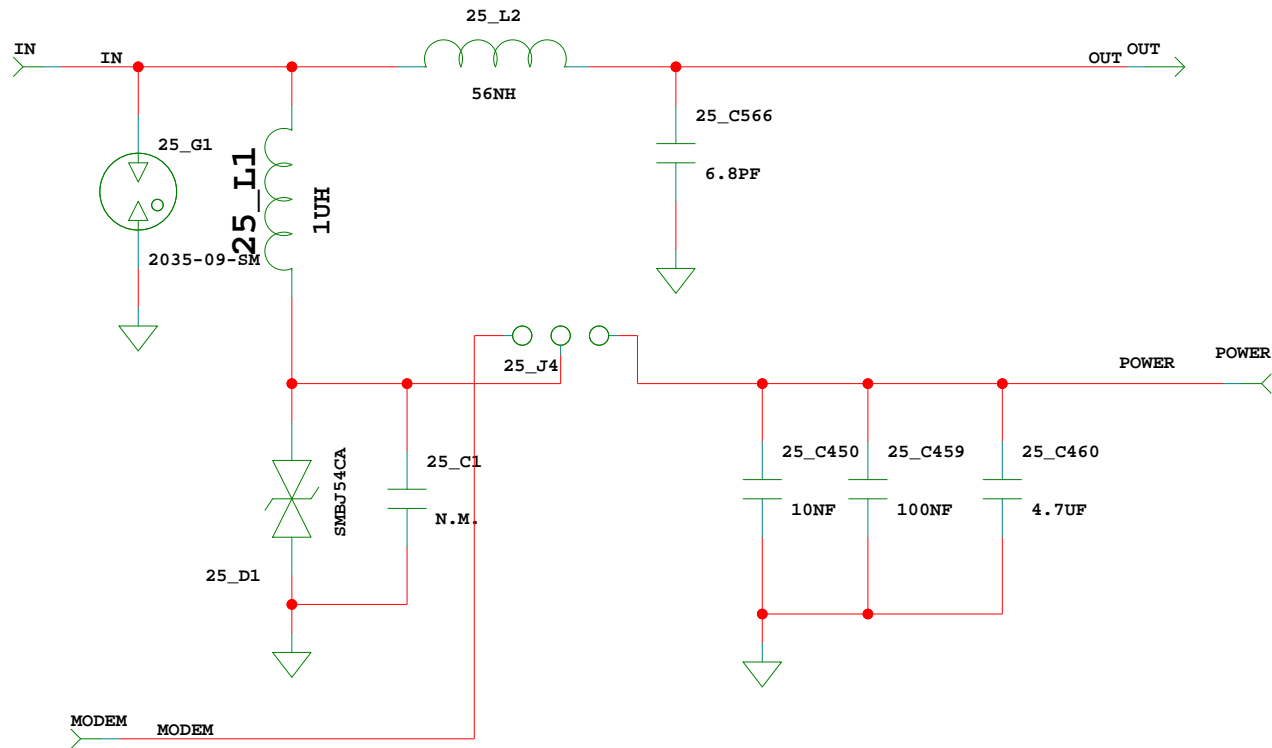

ASTRON / INAF

DESIGN

INPUT SECTION CH0

SIZE

A1

Filename

INPUT_SECTION

REV

3.1

DRAWN BY

Sieds / Gijs

SHEET

34 of 76

DATE

08/04/2022:13:17

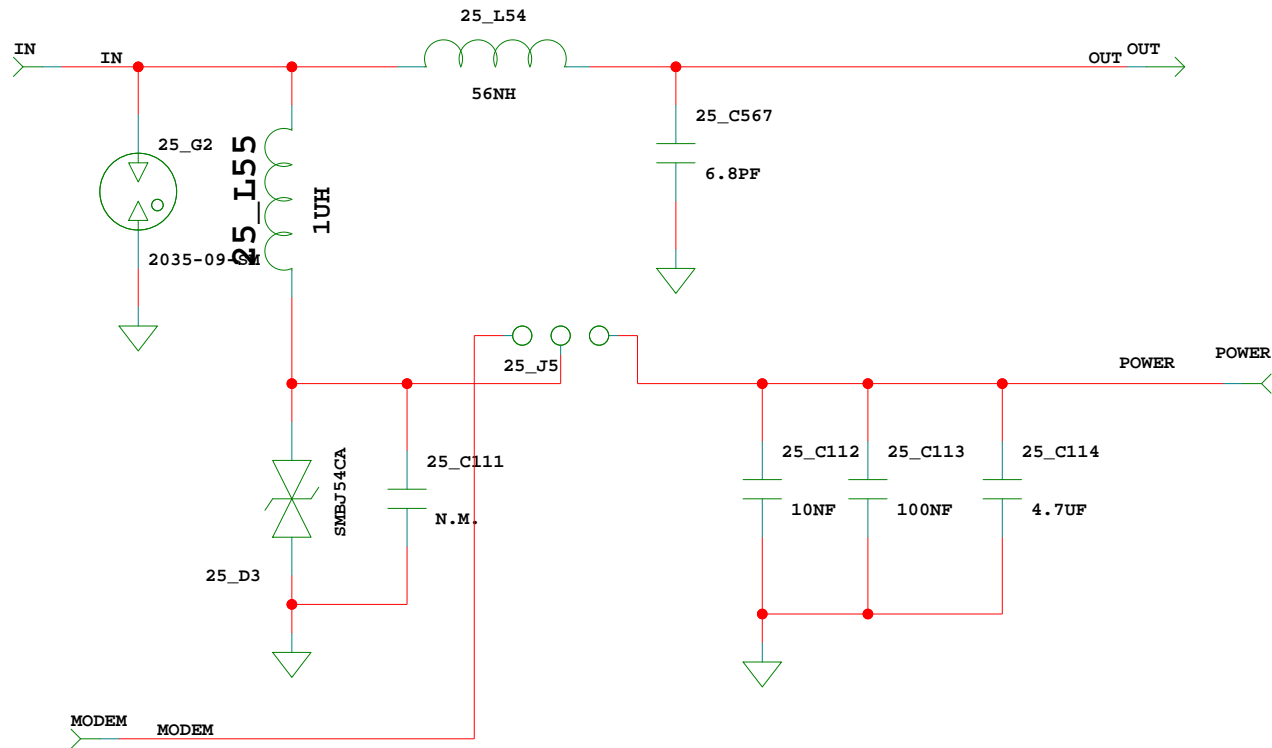

ASTRON / INAF

DESIGN

INPUT SECTION CH1

SIZE

A1

Filename

INPUT_SECTION

REV

3.1

DRAWN BY

Sieds / Gijs

SHEET

35 of 76

DATE

08/04/2022:13:17

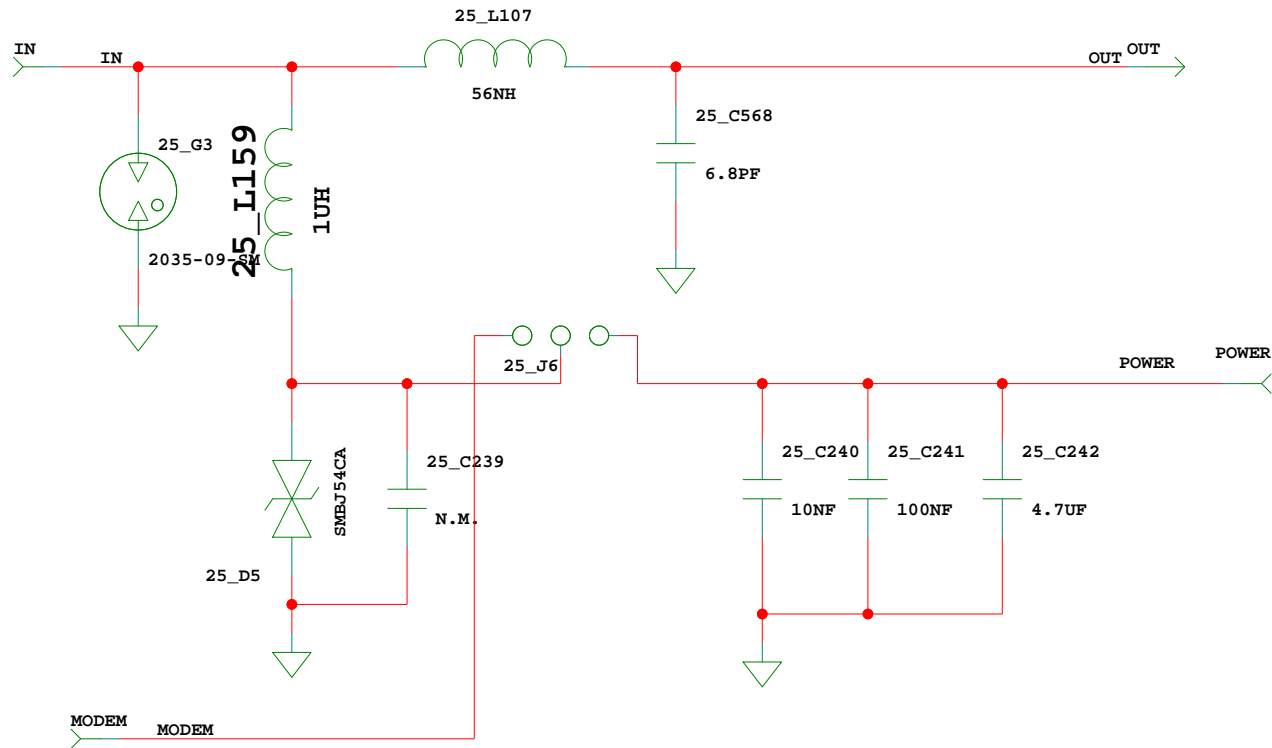

ASTRON / INAF

DESIGN

INPUT SECTION CH2

SIZE

A1

Filename

INPUT_SECTION

REV

3.1

DRAWN BY

Sieds / Gijs

SHEET

36 of 76

DATE

08/04/2022:13:17

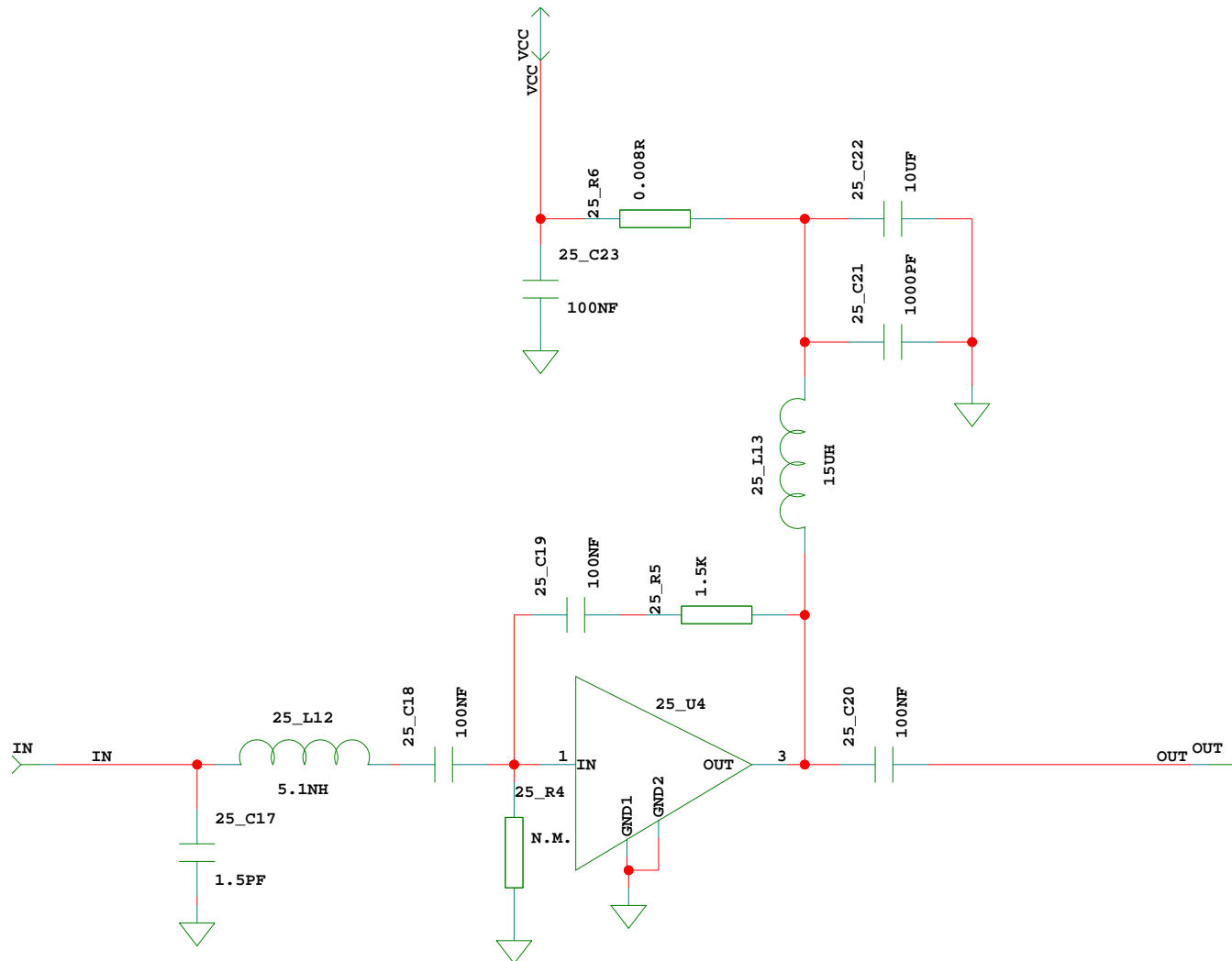

ASTRON / INAF

DESIGN

First Stage Low Noise Amplifier

SIZE

A1

Filename

LNA1

REV

3.1

DRAWN BY
Sieds / Gijs

SHEET 37 of 76

DATE

08/04/2022:13:17

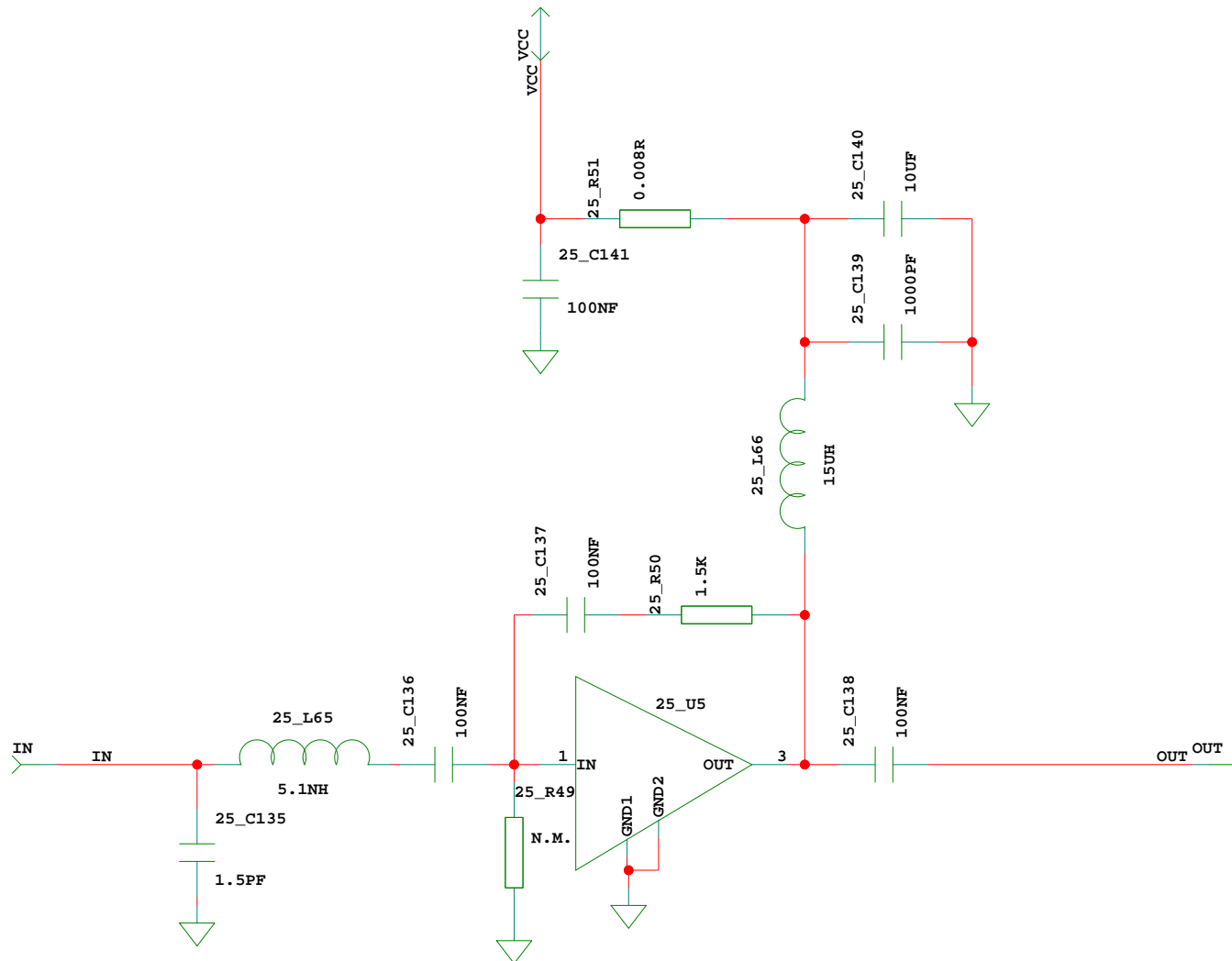

ASTRON / INAF

DESIGN

First Stage Low Noise Amplifier

SIZE

A1

Filename

LNA1

REV

3.1

DRAWN BY
Sieds / Gijs

SHEET 38 of 76

DATE

08/04/2022:13:17

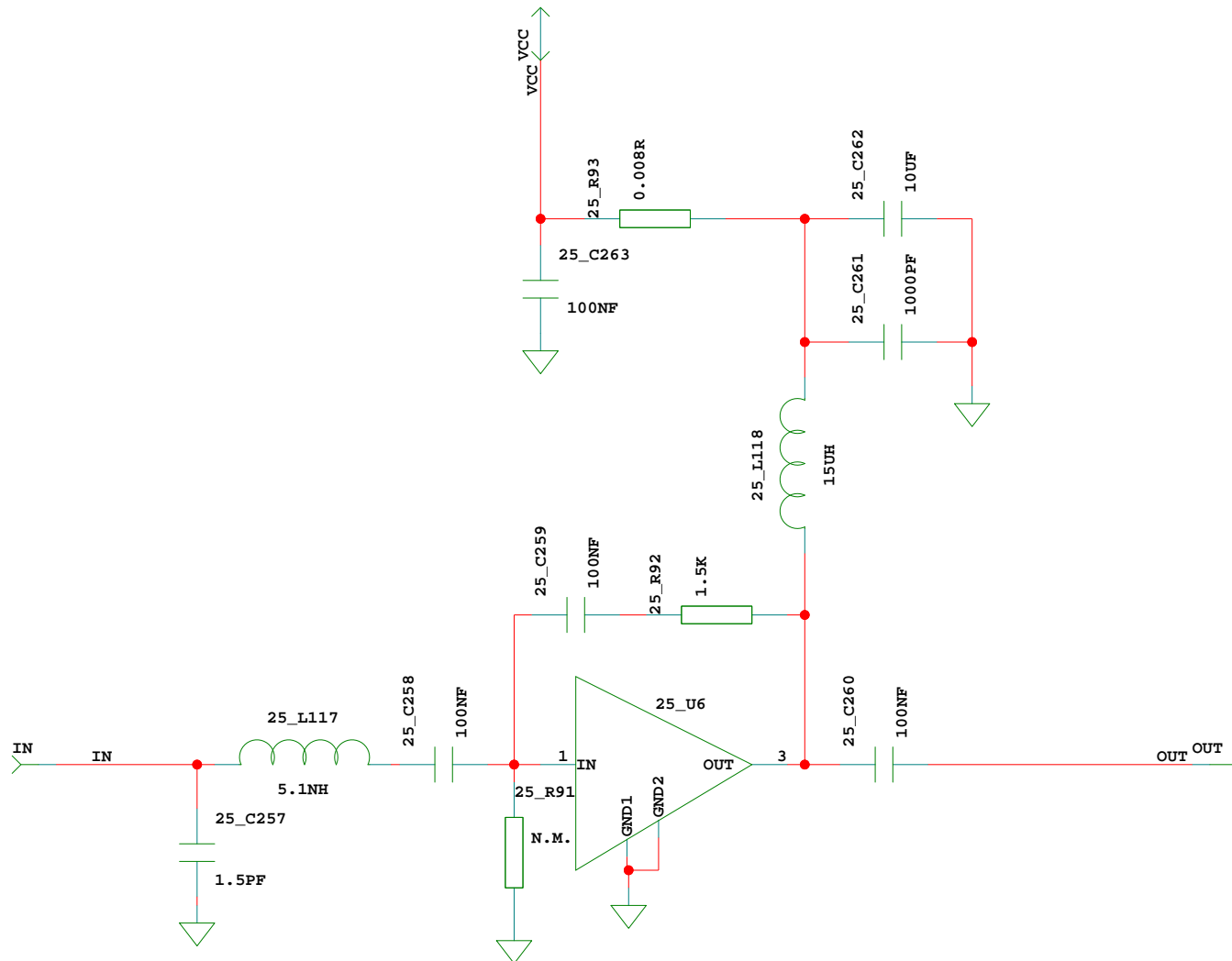

ASTRON / INAF

DESIGN

First Stage Low Noise Amplifier

SIZE

A1

Filename

LNA1

REV

3.1

DRAWN BY
Sieds / Gijs

SHEET 39 of 76

DATE

08/04/2022:13:17

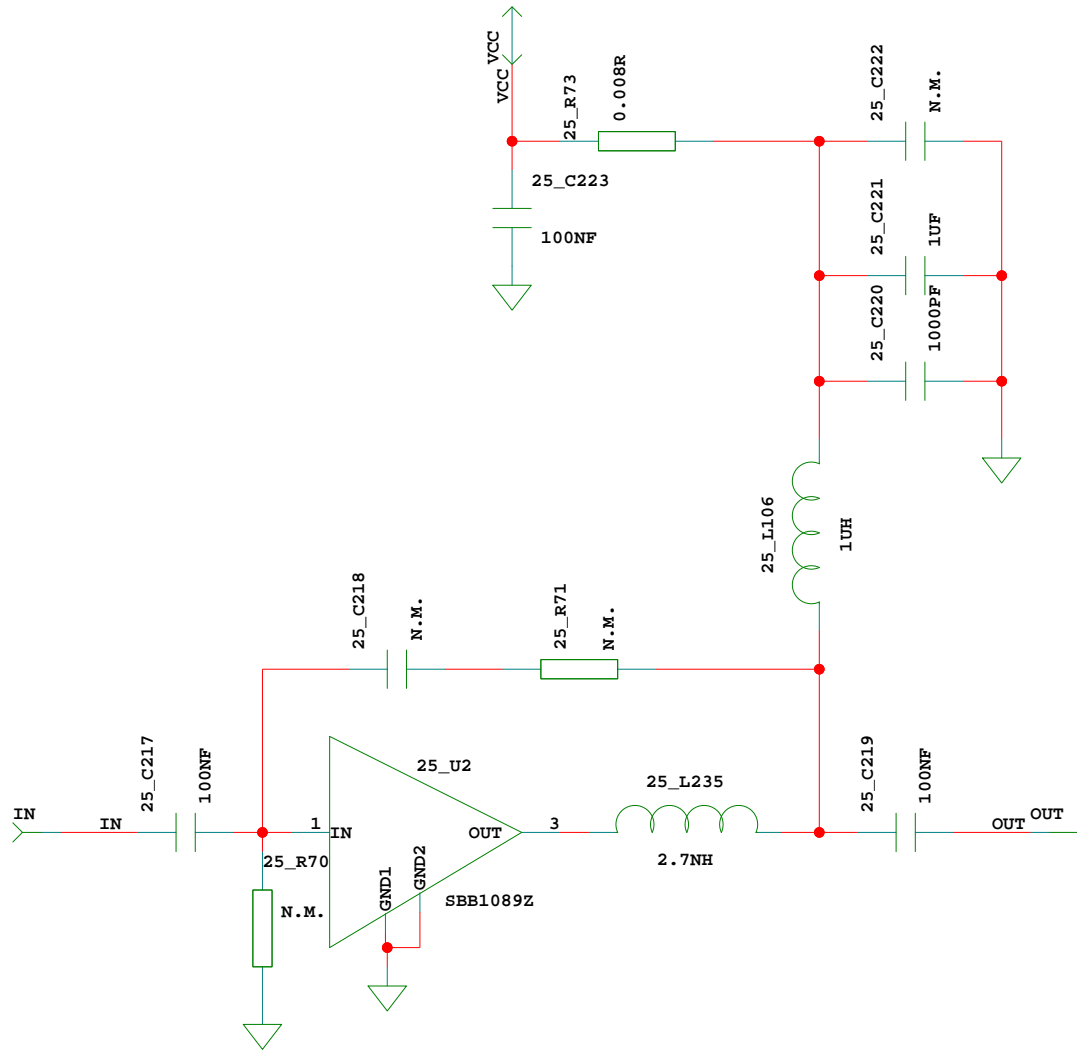

ASTRON

DESIGN

Second Amplifier CH1

SIZE

A1

Filename

LNA3

REV

3.1

DRAWN BY
Sieds / Gijs

SHEET 41 of 76

DATE

08/04/2022:13:16

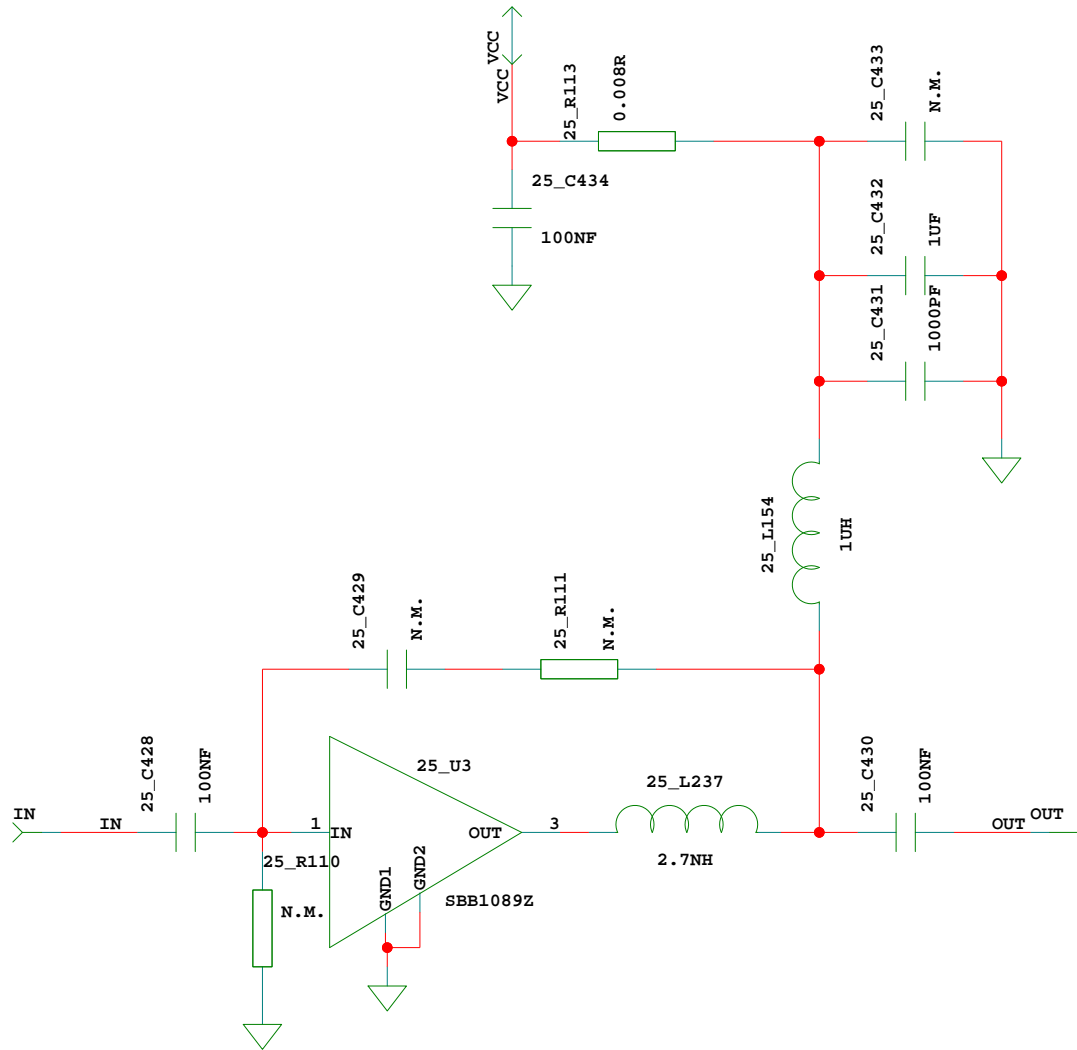

ASTRON

DESIGN

Second Amplifier CH2

SIZE

A1

Filename

LNA3

REV

3.1

DRAWN BY

Sieds / Gijs

SHEET

42 of 76

DATE

08/04/2022:13:16

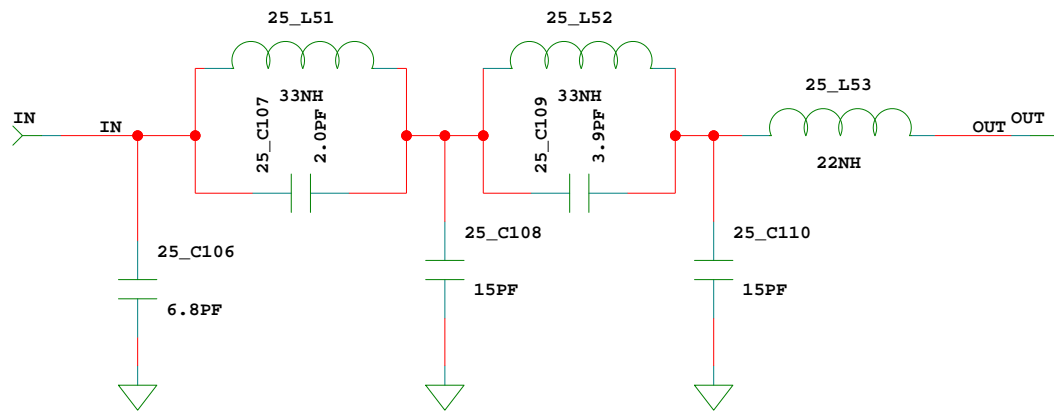

ASTRON / INAF

DESIGN		LP_270_MHz CH0	
SIZE	Filename	REV	
A1	LP_270_MHz	3.1	
DRAWN BY	SHEET	DATE	
Sieds / Gijs	43 of 76	08/04/2022:13:17	

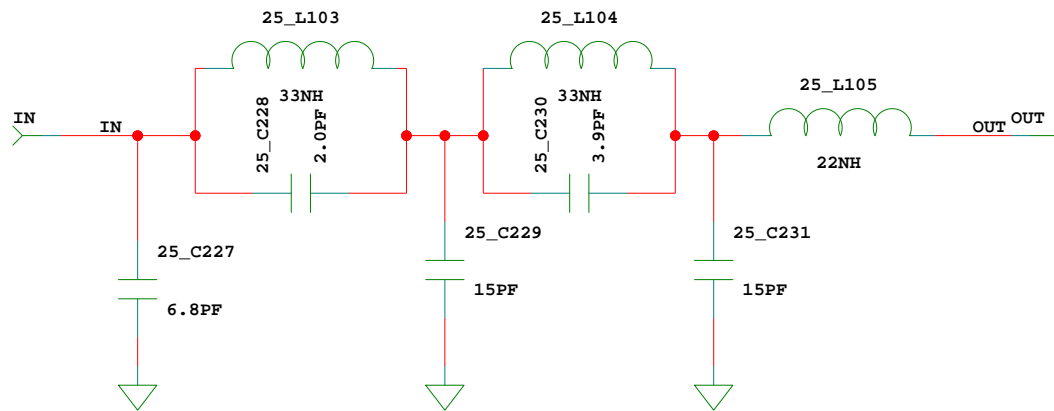

ASTRON / INAF

DESIGN		LP_270_MHz CH1	
SIZE	Filename	REV	
A1	LP_270_MHz	3.1	
DRAWN BY	SHEET	DATE	
Sieds / Gijs	44 of 76	08/04/2022:13:17	

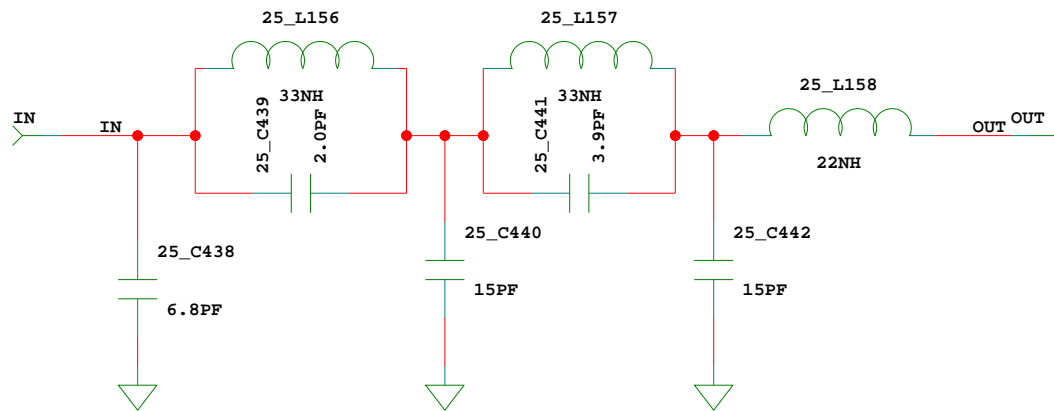

ASTRON / INAF

DESIGN		LP_270_MHz CH2	
SIZE	Filename	REV	
A1	LP_270_MHz	3.1	
DRAWN BY	SHEET	DATE	
Sieds / Gijs	45 of 76	08/04/2022:13:17	

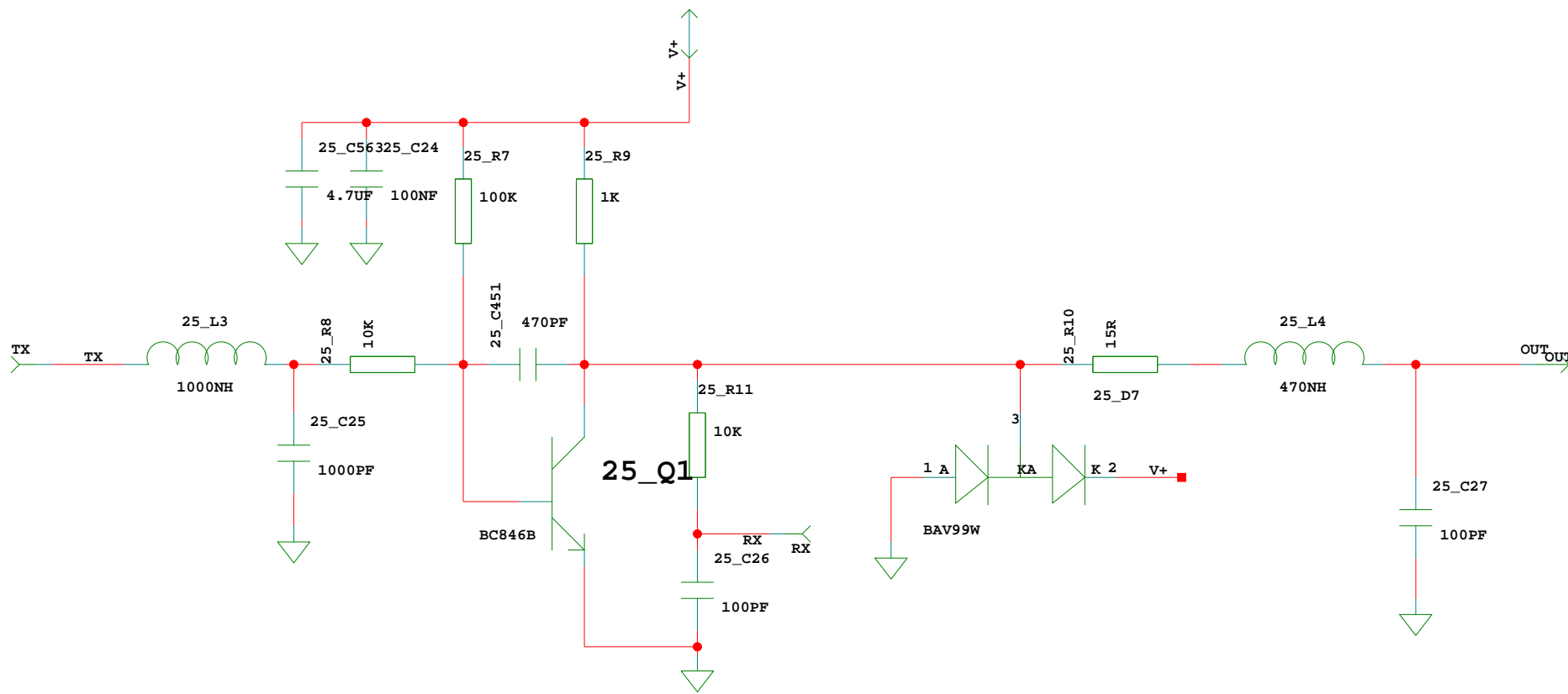

ASTRON / INAF

DESIGN MODEM CH0

SIZE	Filename	REV
A1	MODEM	3.1

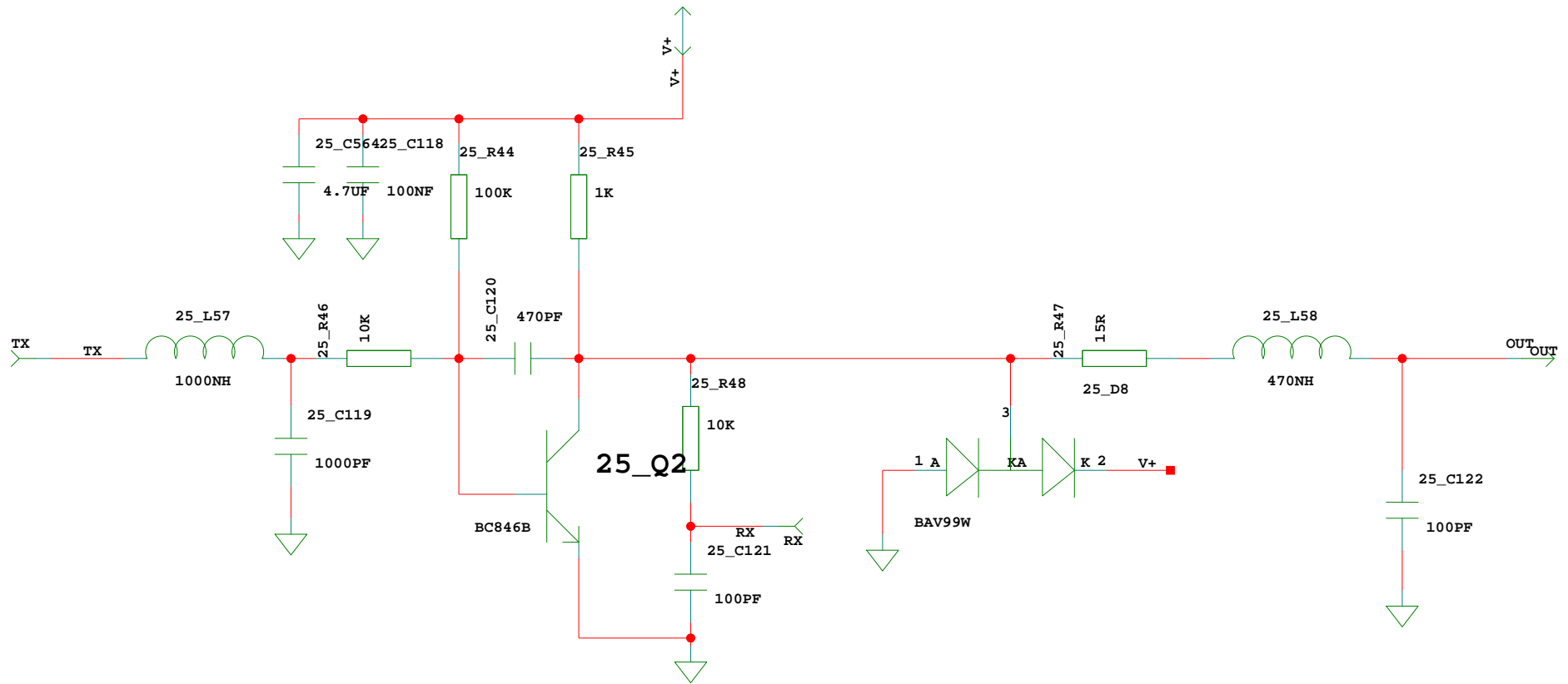

ASTRON / INAF

DESIGN

MODEM CH1

SIZE

A1

Filename

MODEM

REV

3.1

DRAWN BY

Sieds / Gijs

SHEET

47 of 76

DATE

08/04/2022:13:16

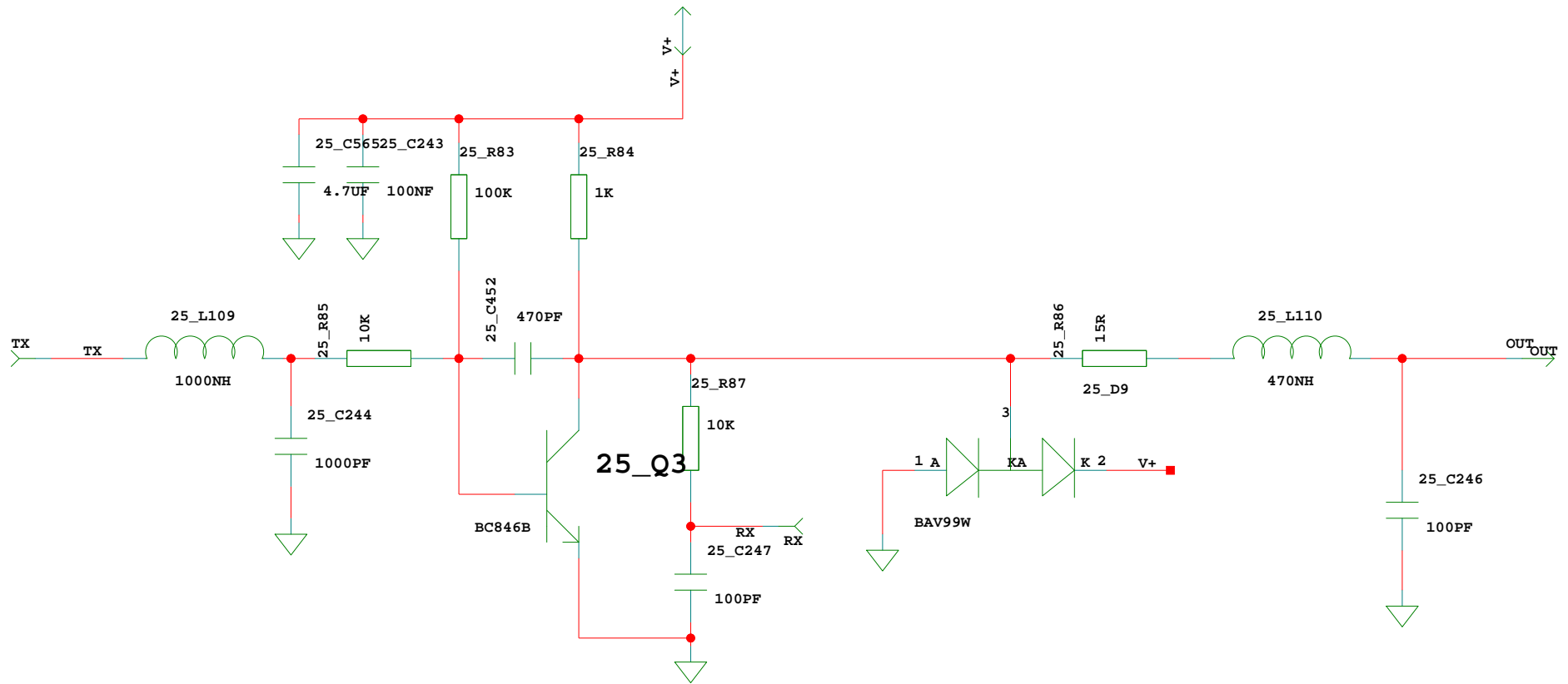

ASTRON / INAF

DESIGN

MODEM CH2

SIZE

A1

Filename

MODEM

REV

3.1

DRAWN BY

Sieds / Gijs

SHEET

48 of 76

DATE

08/04/2022:13:16

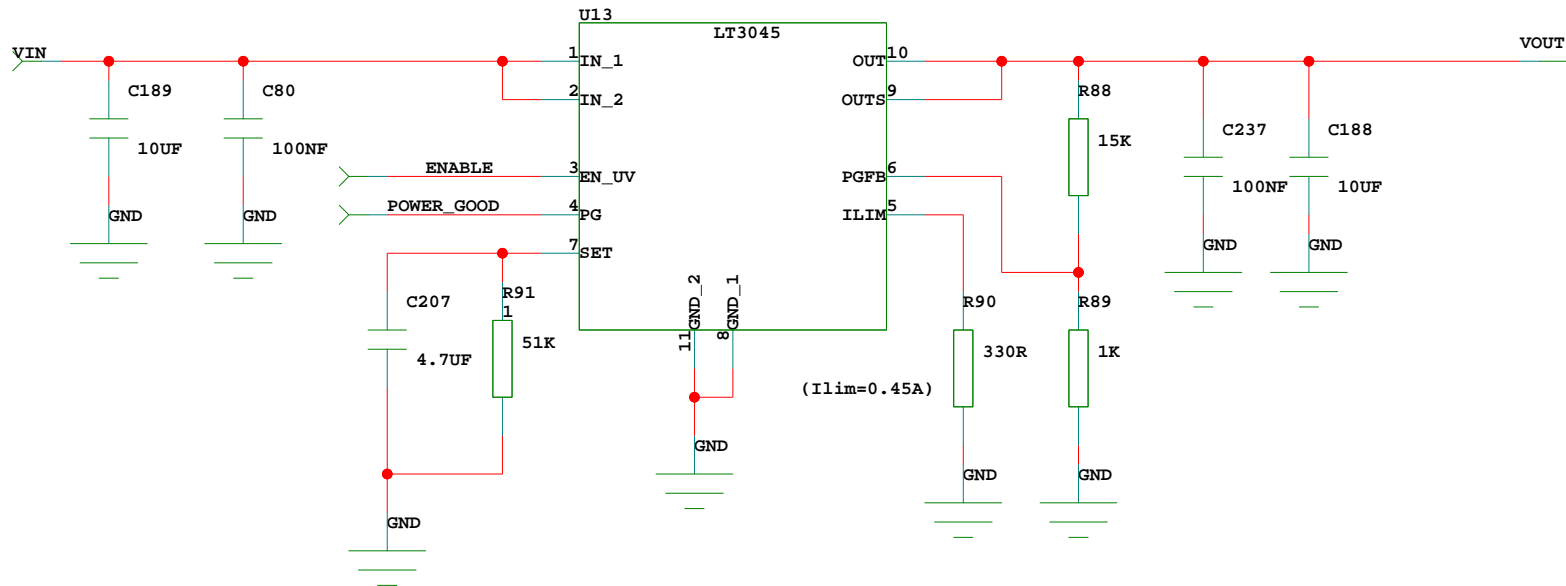

$$V_{good} = 0.3 \left(1 + \frac{R_{high}}{R_{low}} \right)$$

$$V_{out} = 100\mu A \cdot R_{set}$$

$$I_{lim} = 150\text{mA} \cdot 1e3 / R_{lim}$$

Vout	Rset	ASTRON nr	Vgood	Rhigh	ASTRON nr
5V0	51K	AST02179	4V8	15K	AST01540
3V3	33K2	AST02177	2V8	8K2	AST01333
2V5	25K5	AST02176	2V3	6K8	AST02163
1V8	18K	AST02178	1V7	4K7	AST01979

ASTRON

DESIGN

VCC Analog Buffer Channel 0

SIZE

A1

Filename

LDO_POWERSUPPLY

REV

3.1

DRAWN BY

Sieds / Gijs

SHEET

49 of 76

DATE

08/04/2022:13:16

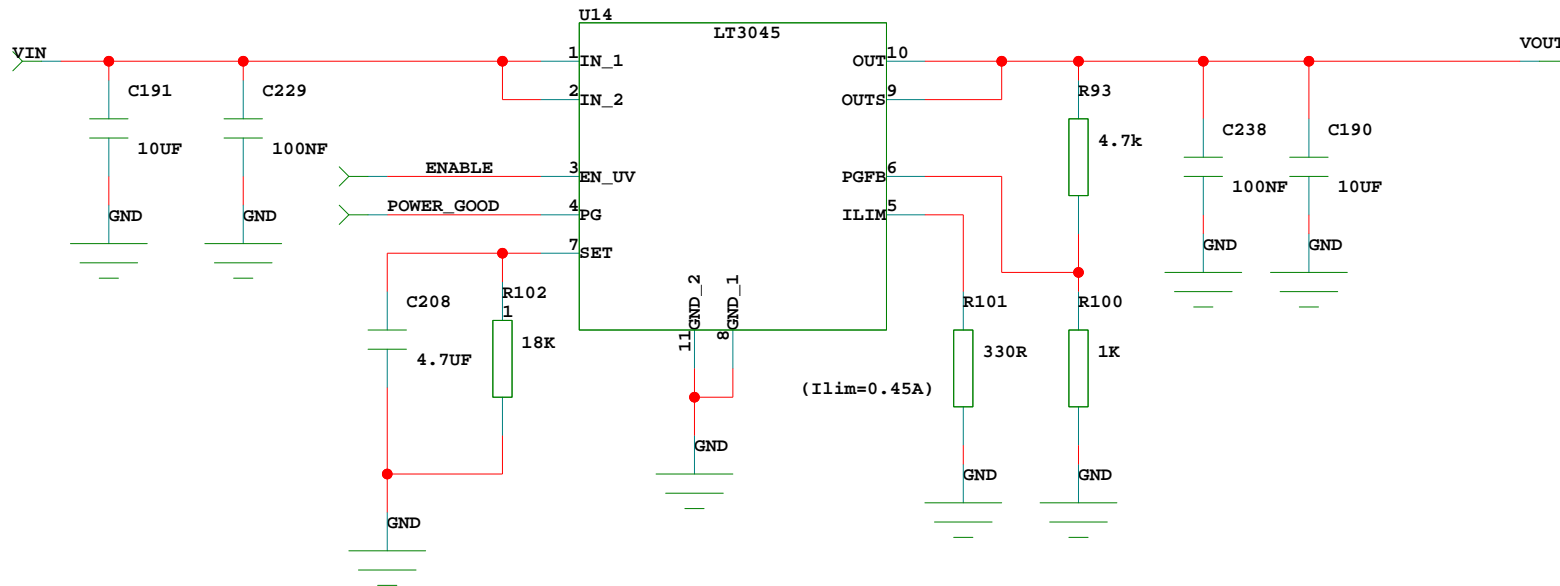

$$V_{good} = 0.3 \left(1 + \frac{R_{high}}{R_{low}} \right)$$

$$V_{out} = 100\mu A \cdot R_{set}$$

$$I_{lim} = 150\text{mA} \cdot 1e3 / R_{lim}$$

Vout	Rset	ASTRON nr	Vgood	Rhigh	ASTRON nr
5V0	51K	AST02179	4V8	15K	AST01540
3V3	33K2	AST02177	2V8	8K2	AST01333
2V5	25K5	AST02176	2V3	6K8	AST02163
1V8	18K	AST02178	1V7	4K7	AST01979

ASTRON

DESIGN

VCC Analog Buffer Channel 0

SIZE

A1

Filename

LDO_POWERSUPPLY

REV

3.1

DRAWN BY

Sieds / Gijs

SHEET

50 of 76

DATE

08/04/2022:13:16

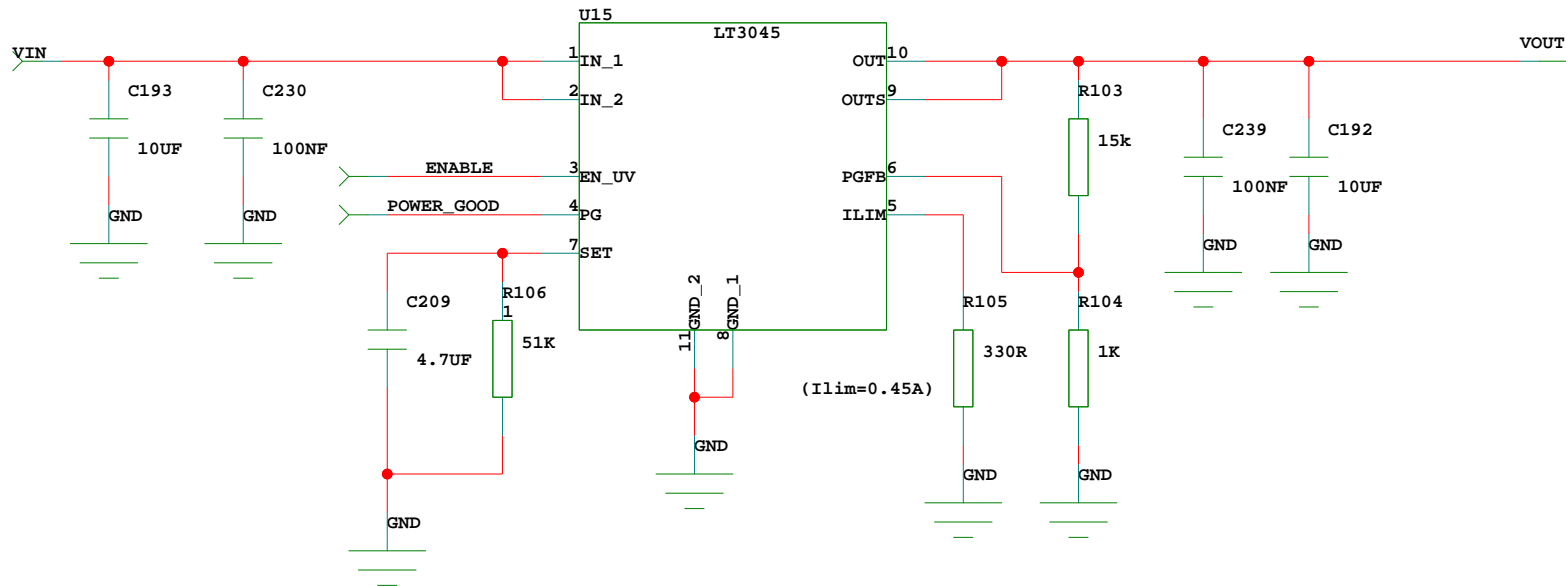

$$V_{good} = 0.3 \left(1 + \frac{R_{high}}{R_{low}} \right)$$

$$V_{out} = 100\mu A \cdot R_{set}$$

$$I_{lim} = 150mA \cdot 1e3 / R_{lim}$$

Vout	Rset	ASTRON nr	Vgood	Rhigh	ASTRON nr
5V0	51K	AST02179	4V8	15K	AST01540
3V3	33K2	AST02177	2V8	8K2	AST01333
2V5	25K5	AST02176	2V3	6K8	AST02163
1V8	18K	AST02178	1V7	4K7	AST01979

ASTRON

DESIGN

VCC Analog Buffer Channel 1

SIZE

A1

Filename

LDO_POWERSUPPLY

REV

3.1

DRAWN BY

Sieds / Gijs

SHEET

51 of 76

DATE

08/04/2022:13:16

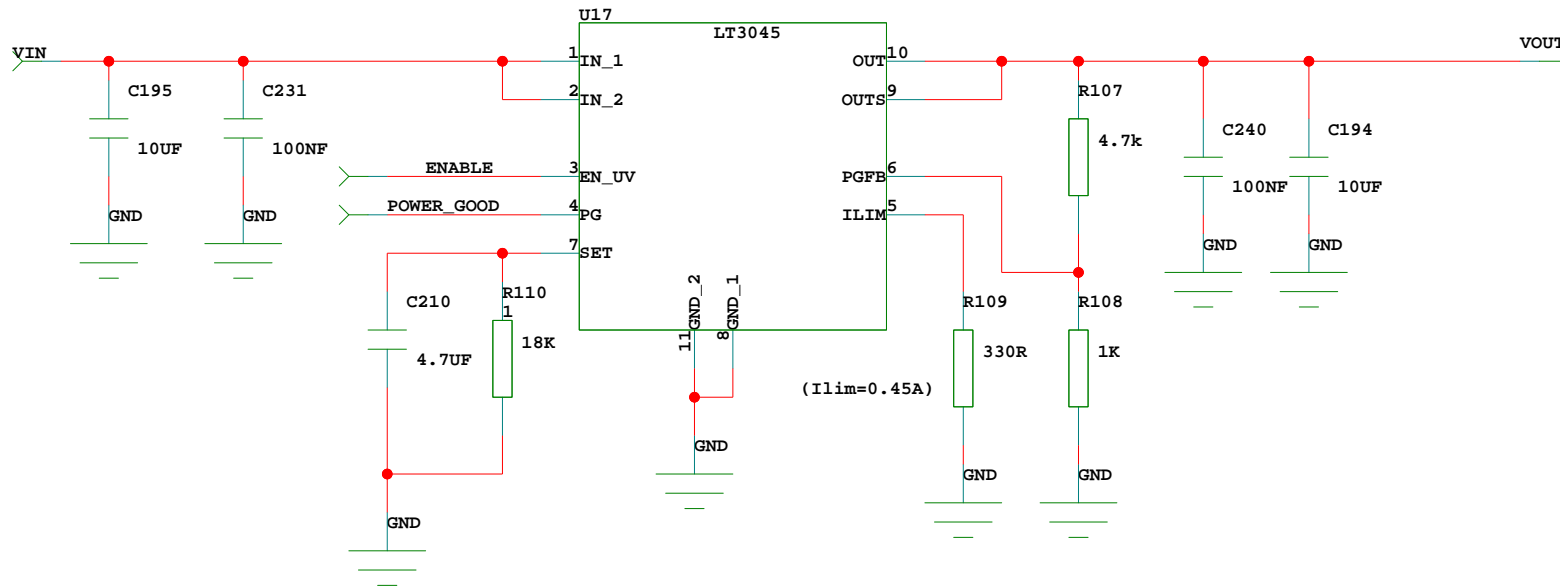

$$V_{good} = 0.3 \left(1 + \frac{R_{high}}{R_{low}} \right)$$

$$V_{out} = 100\mu A \cdot R_{set}$$

$$I_{lim} = 150\text{mA} \cdot 1e3 / R_{lim}$$

Vout	Rset	ASTRON nr	Vgood	Rhigh	ASTRON nr
5V0	51K	AST02179	4V8	15K	AST01540
3V3	33K2	AST02177	2V8	8K2	AST01333
2V5	25K5	AST02176	2V3	6K8	AST02163
1V8	18K	AST02178	1V7	4K7	AST01979

ASTRON

DESIGN

VCC Analog Buffer Channel 1

SIZE

A1

Filename

LDO_POWERSUPPLY

REV

3.1

DRAWN BY

Sieds / Gijs

SHEET

52 of 76

DATE

08/04/2022:13:16

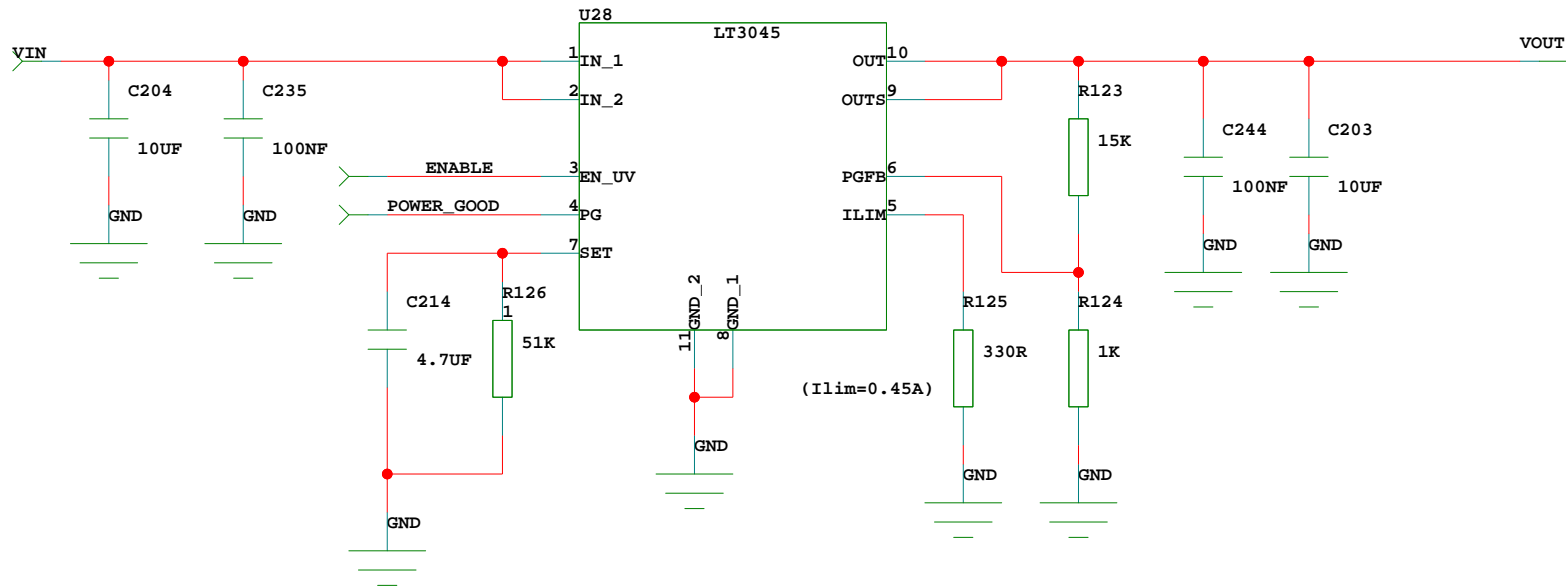

$$V_{good} = 0.3 \left(1 + \frac{R_{high}}{R_{low}} \right)$$

$$V_{out} = 100\mu A \cdot R_{set}$$

$$I_{lim} = 150\text{mA} \cdot 1e3 / R_{lim}$$

Vout	Rset	ASTRON nr	Vgood	Rhigh	ASTRON nr
5V0	51K	AST02179	4V8	15K	AST01540
3V3	33K2	AST02177	2V8	8K2	AST01333
2V5	25K5	AST02176	2V3	6K8	AST02163
1V8	18K	AST02178	1V7	4K7	AST01979

ASTRON

DESIGN

VCC Analog Buffer Channel 2

SIZE

A1

Filename

LDO_POWERSUPPLY

REV

3.1

DRAWN BY

Sieds / Gijs

SHEET

53 of 76

DATE

08/04/2022:13:16

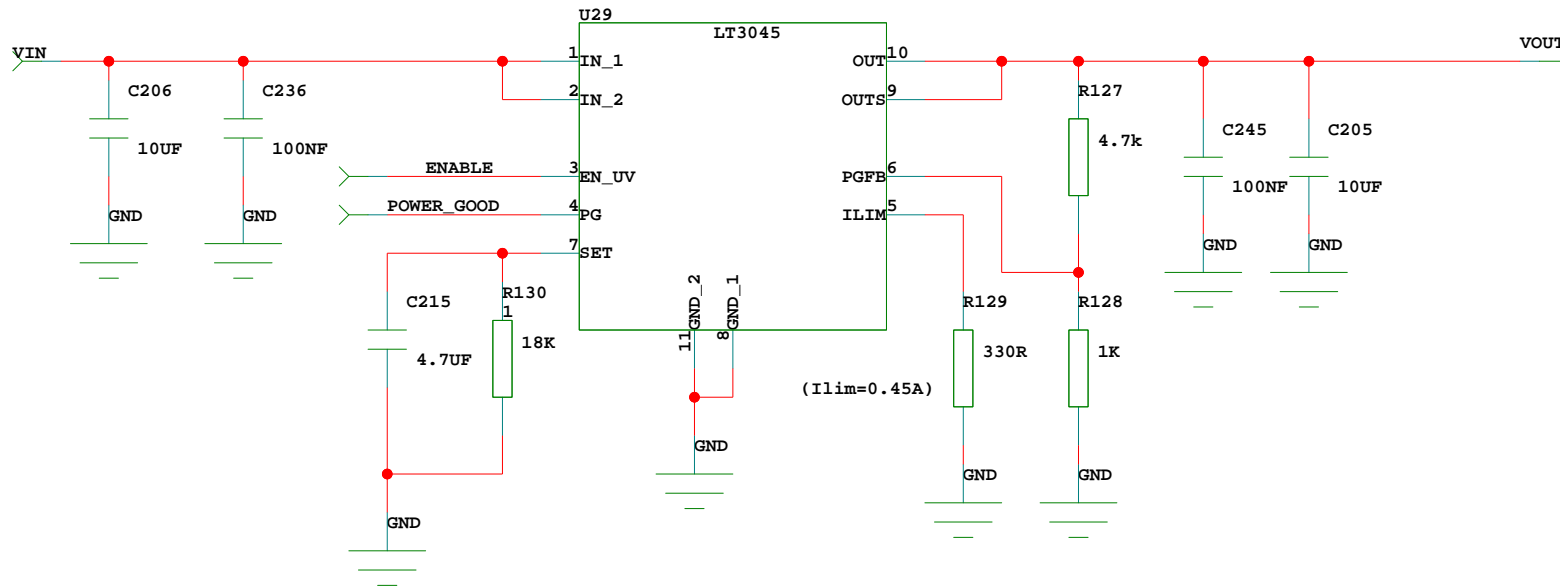

$$V_{good} = 0.3 \left(1 + \frac{R_{high}}{R_{low}} \right)$$

$$V_{out} = 100\mu A \cdot R_{set}$$

$$I_{lim} = 150\text{mA} \cdot 1e3 / R_{lim}$$

Vout	Rset	ASTRON nr	Vgood	Rhigh	ASTRON nr
5V0	51K	AST02179	4V8	15K	AST01540
3V3	33K2	AST02177	2V8	8K2	AST01333
2V5	25K5	AST02176	2V3	6K8	AST02163
1V8	18K	AST02178	1V7	4K7	AST01979

ASTRON

DESIGN

VCC Analog Buffer Channel 2

SIZE

A1

Filename

LDO_POWERSUPPLY

REV

3.1

DRAWN BY

Sieds / Gijs

SHEET

54 of 76

DATE

08/04/2022:13:16

1

2

3

4

5

E

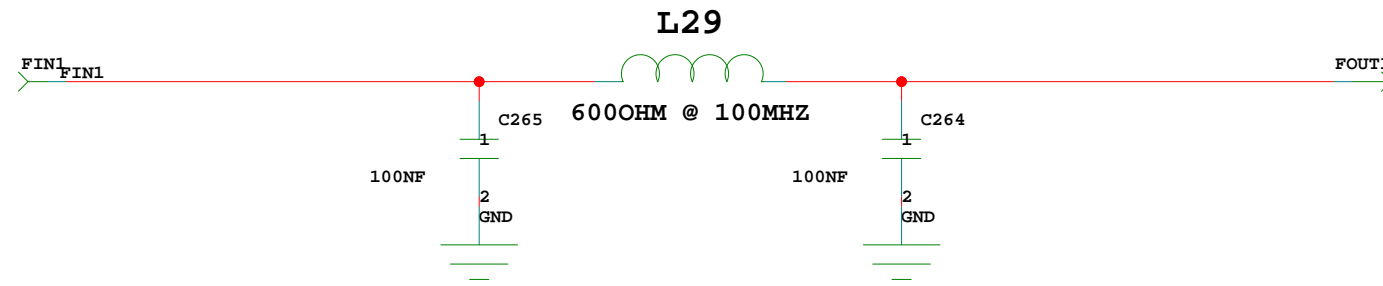

D

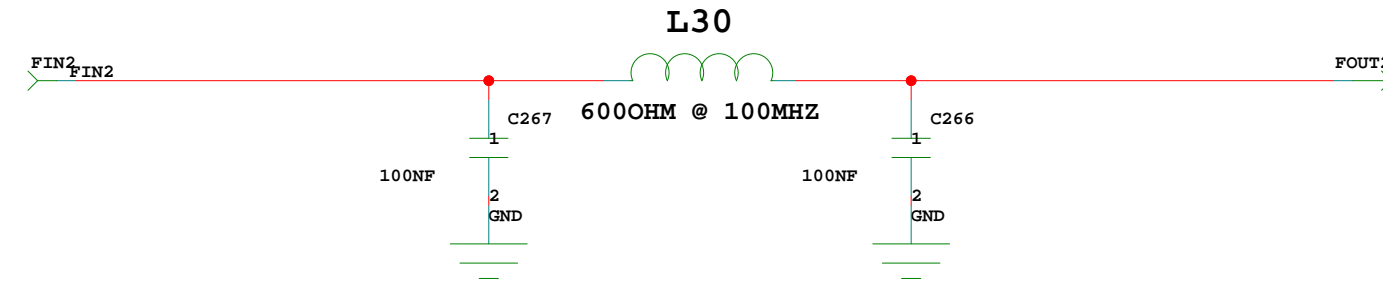

C

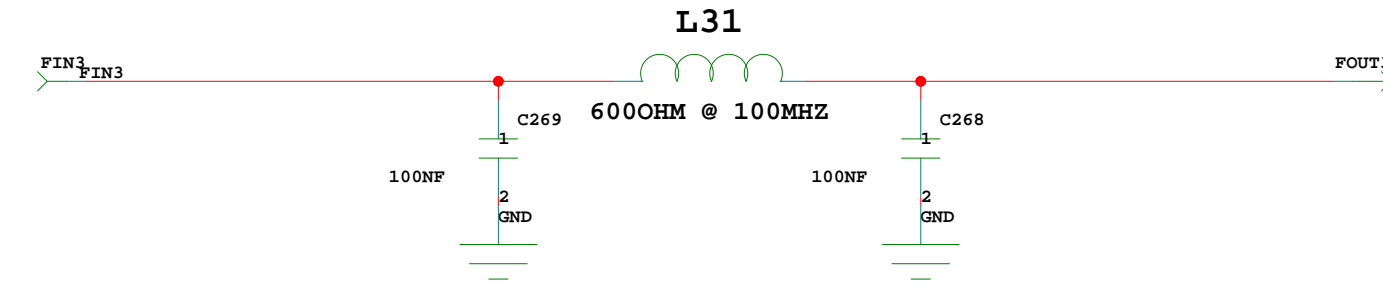

B

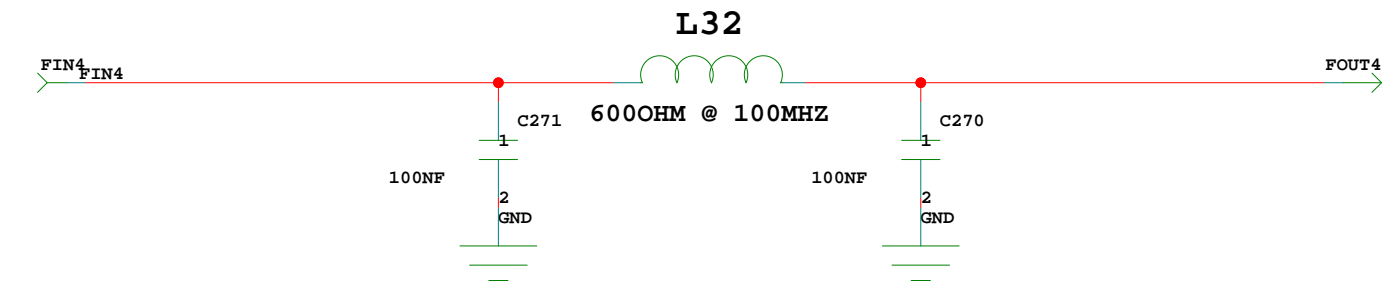

A

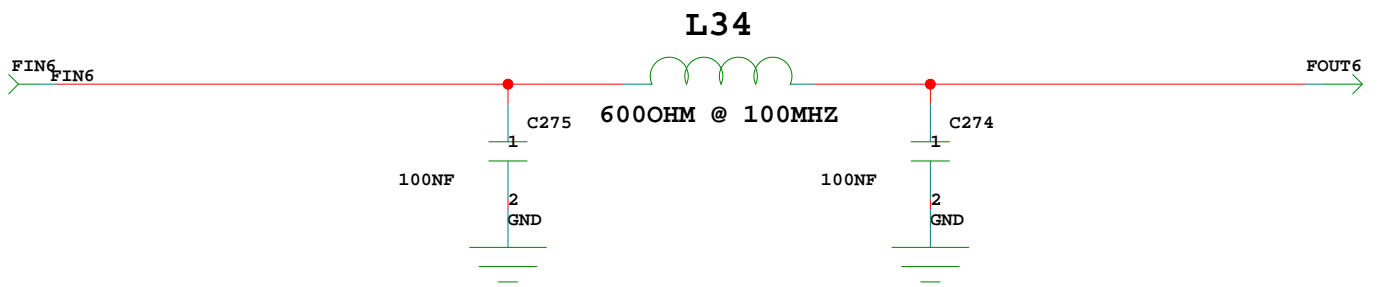
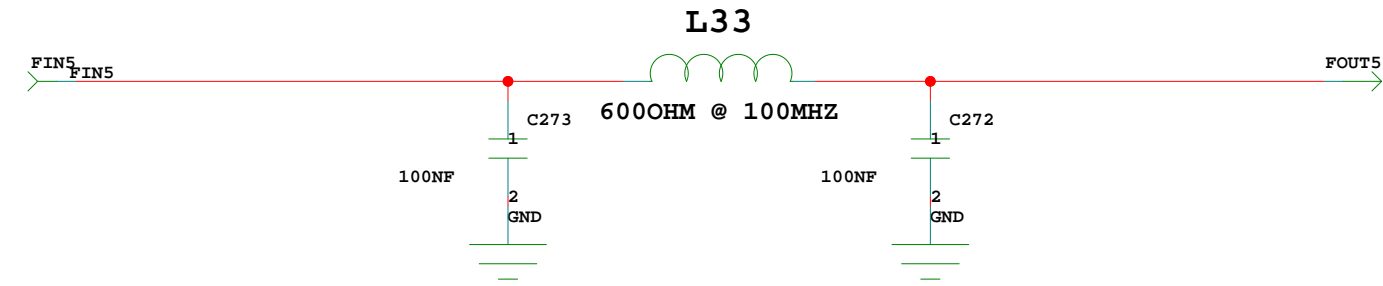

ASTRON

DESIGN Filter Datalines Band selection CH

SIZE A3	Filename	CLC_NETWORK	REV 3.1
-------------------	----------	--------------------	-------------------

DRAWN BY Sieds / Gijs	SHEET 55 of 76	DATE 08/04/2022:13:19
--------------------------	----------------	--------------------------

1

2

3

4

5

E

D

C

B

A

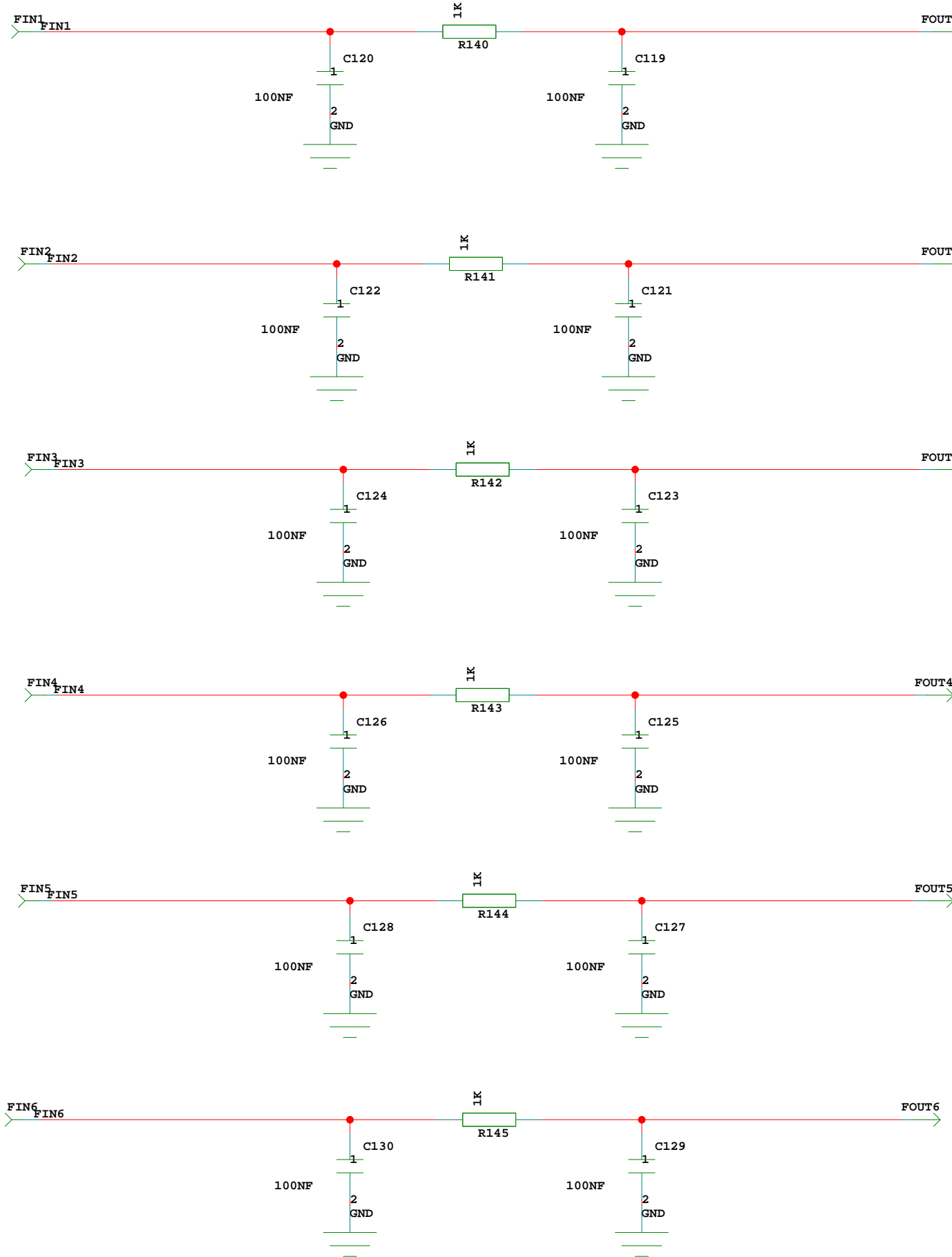

ASTRON

Filter Datalines AD

DESIGN	CRC_NETWORK		REV	3.1
SIZE	Filename	SHEET		DATE
A3		56 of 76	08/04/2022:13:16	
DRAWN BY Sieds / Gijs				

1

2

3

4

5

E

D

C

B

A

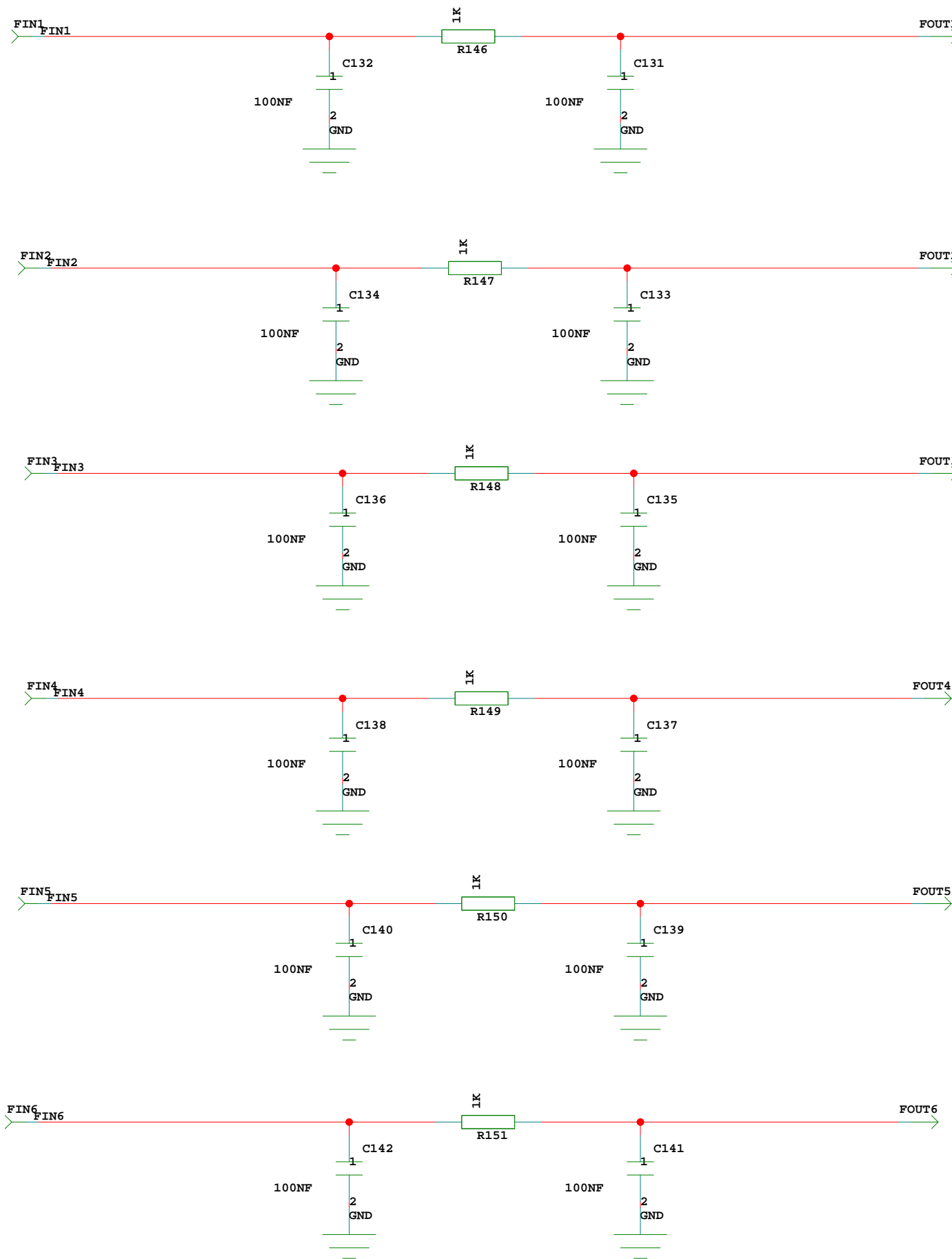

ASTRON

Filter Datalines AD

DESIGN	CRC_NETWORK		REV	3.1
SIZE	Filename	SHEET		DATE
A3		57 of 76	08/04/2022:13:16	
DRAWN BY Sieds / Gijs				

1

2

3

4

5

E

D

C

B

A

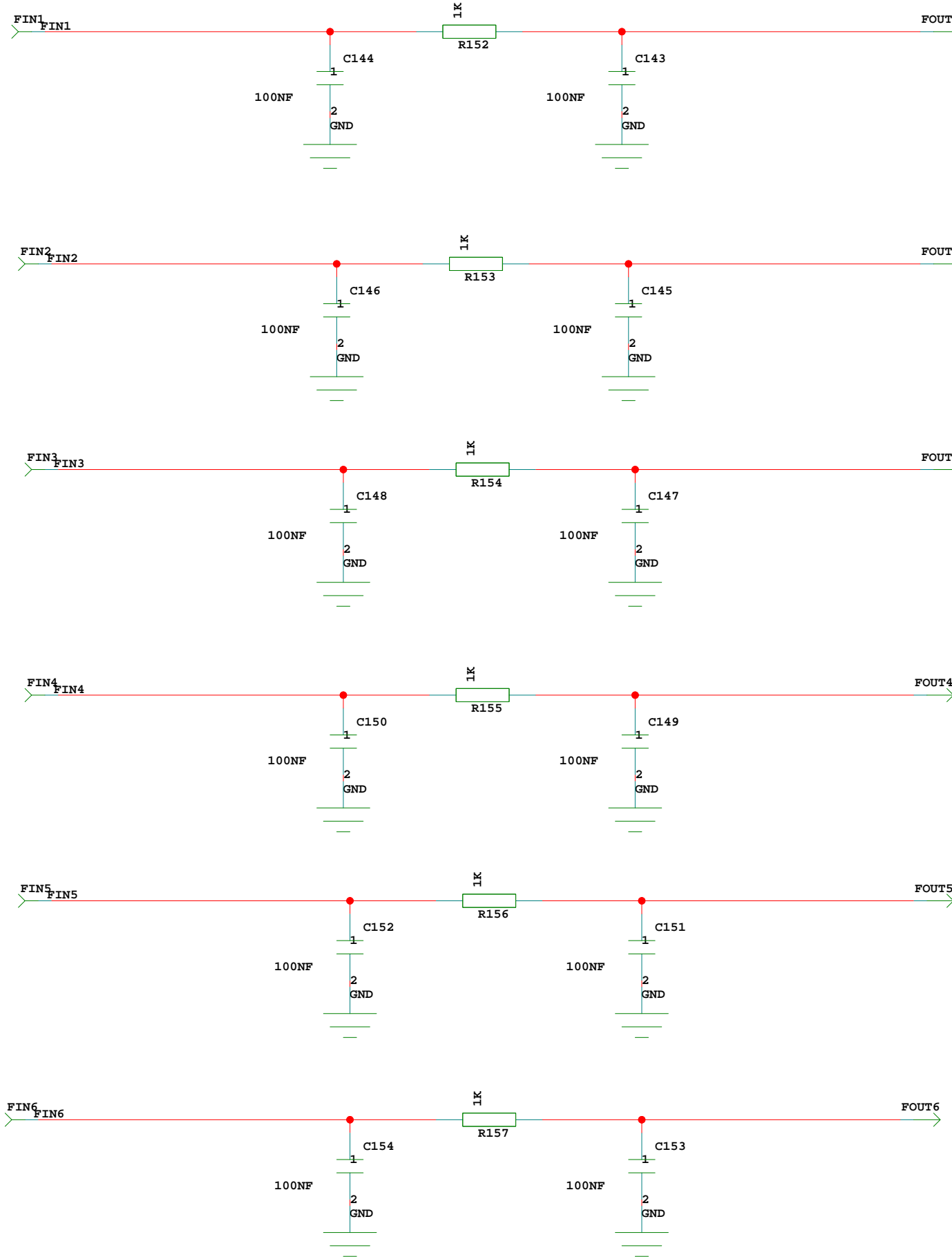

<h1>ASTRON</h1>			
DESIGN			
<h2>Filter Datalines AD</h2>			
SIZE	Filename	REV	
A3		CRC_NETWORK	
DRAWN BY		SHEET	DATE
Sieds / Gijs		58 of 76	08/04/2022:13:16
		3.1	

1

2

3

4

5

E

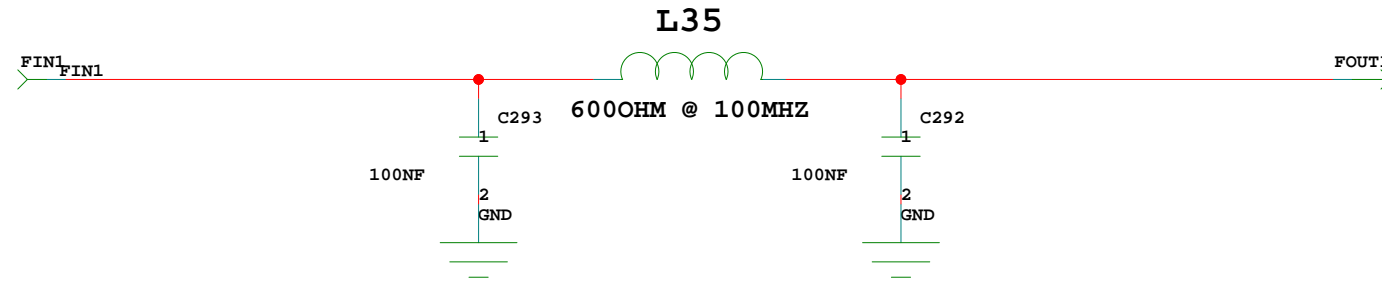

D

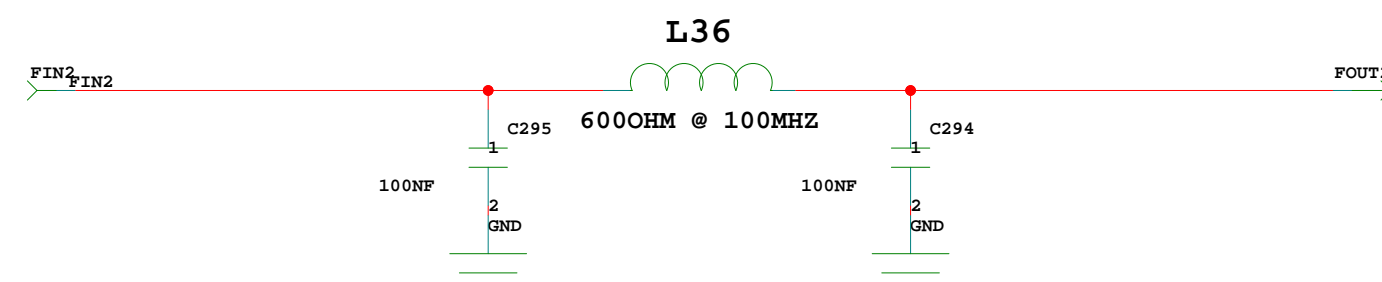

C

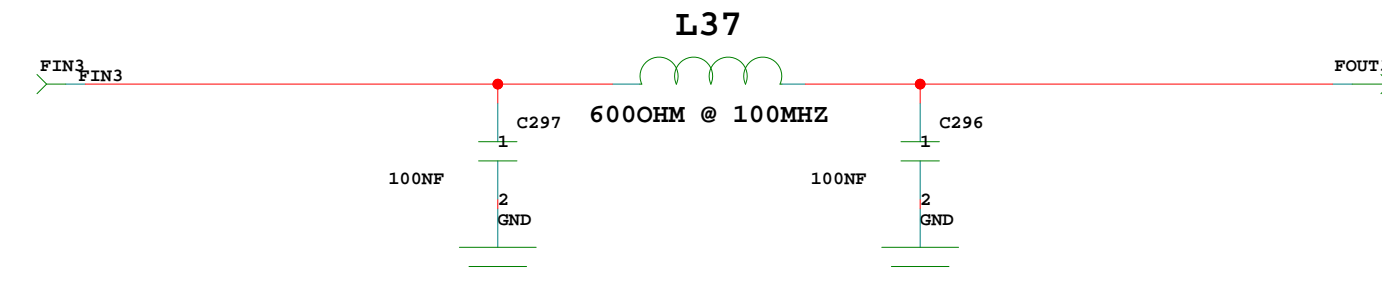

B

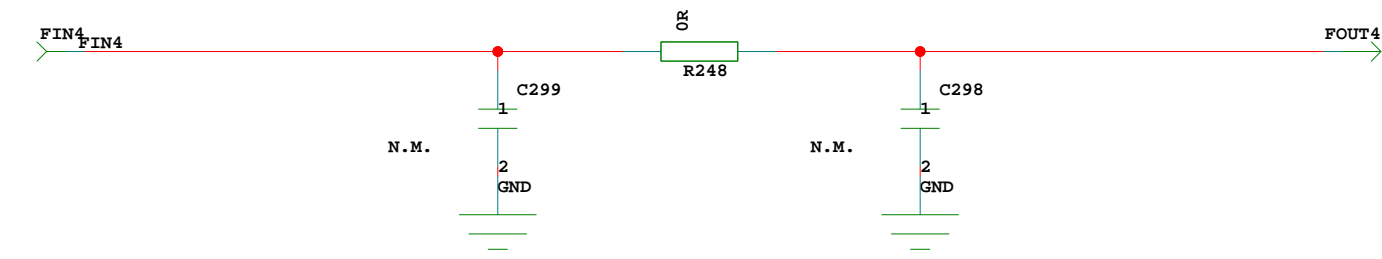

A

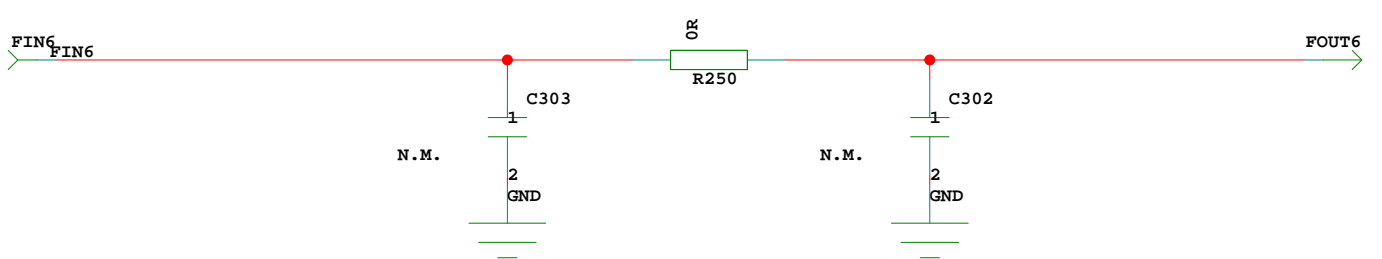
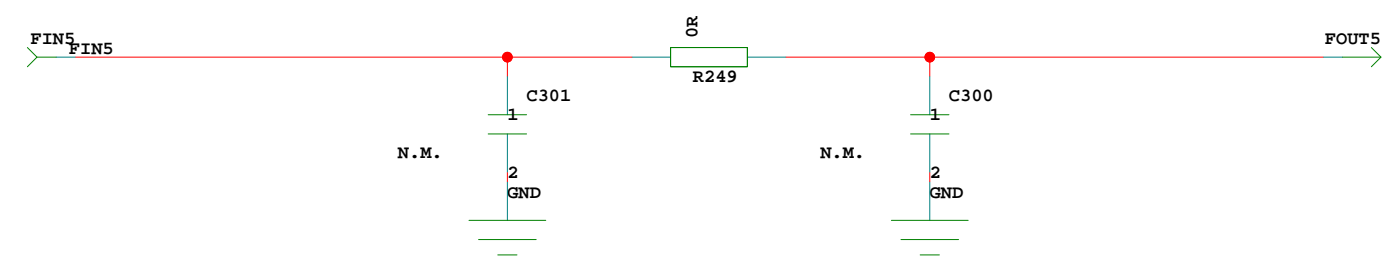

ASTRON

DESIGN Filter Datalines Band Sel. CH2 + O

SIZE A3	Filename	REV 3.1
CLRC_NETWORK		

1

2

3

4

5

E

D

C

B

A



ASTRON

Filter Datalines DA

DESIGN	CRC_NETWORK		REV	3.1
SIZE	Filename	SHEET		DATE
A3		60 of 76	08/04/2022:13:16	
DRAWN BY Sieds / Gijs				

1

2

3

4

5

E

D

C

B

A

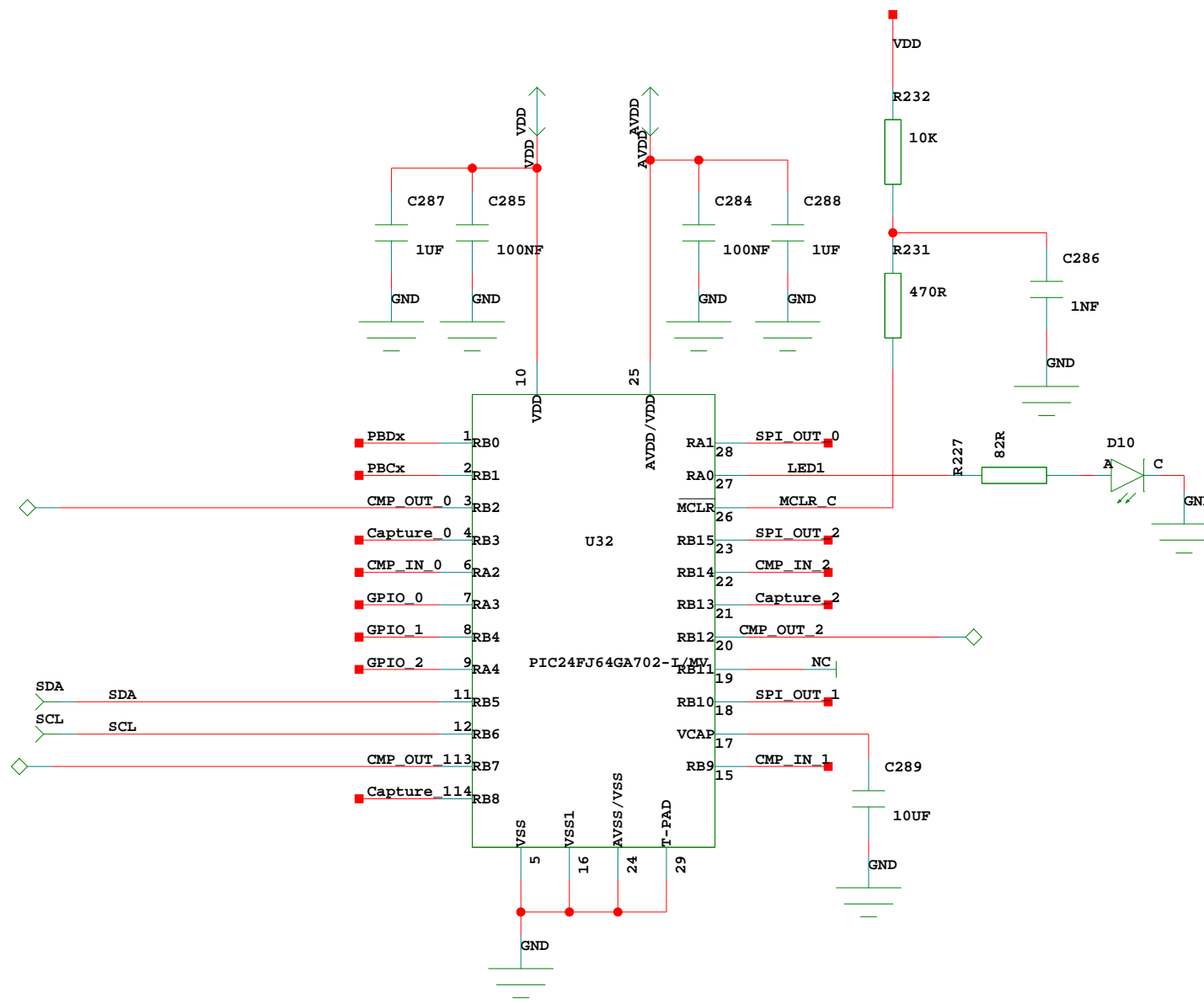
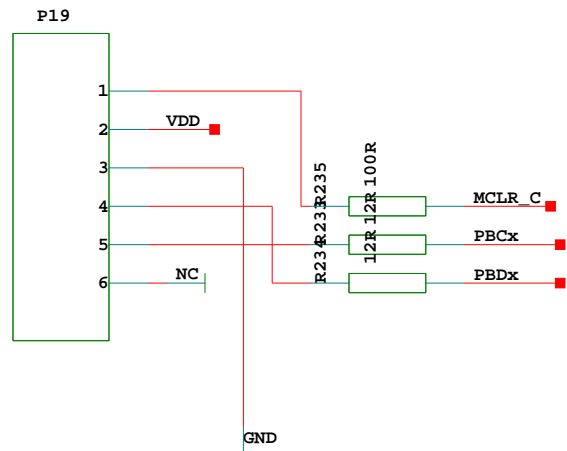

GPIO_[2:0]BGPIO_[2:0]

SPI_OUT_2
 SPI_OUT_1
 SPI_OUT_0

SPI_OUT_[2:0]

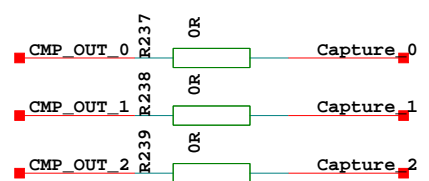
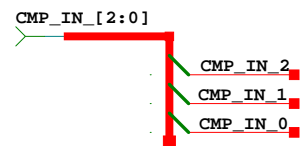
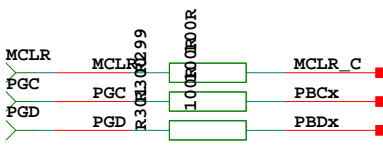

<h1>ASTRON</h1>		
DESIGN Microcontroller PIC24FJ64GA702-I/MV		
SIZE A3	Filename Microcontroller	REV 3.1
DRAWN BY Sieds / Gijs	SHEET 61 of 76	DATE 08/04/2022:13:17

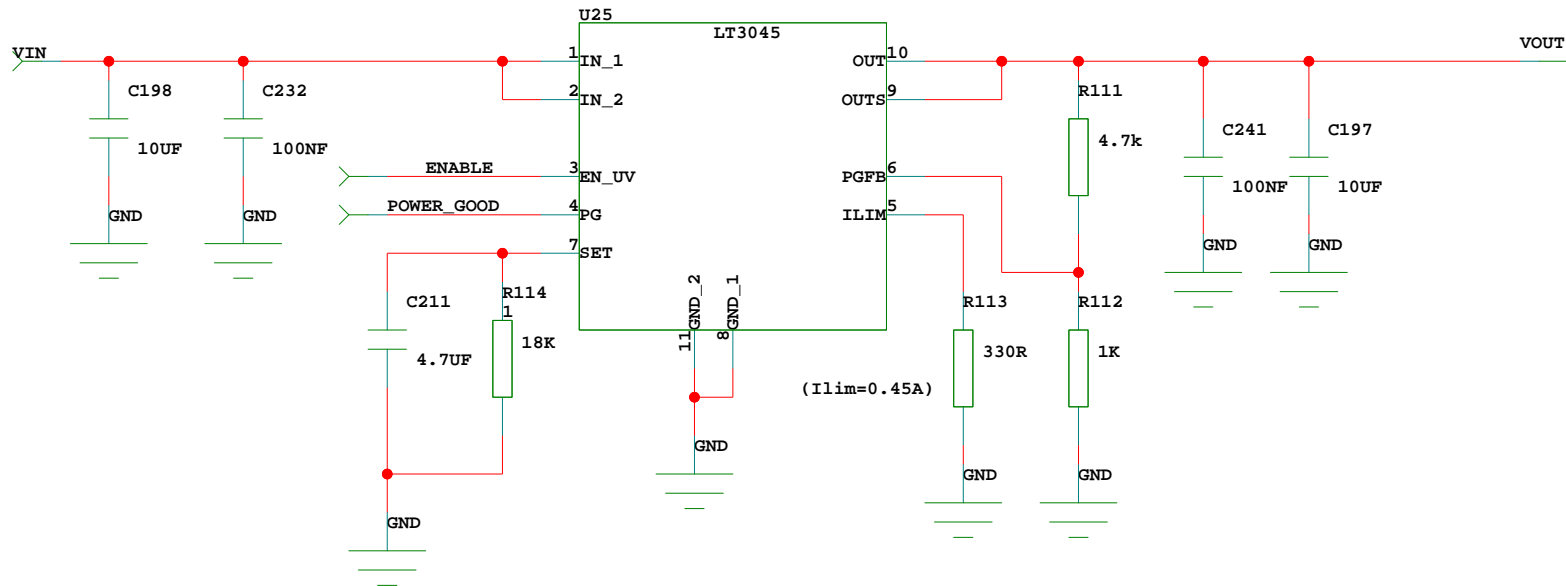

$$V_{good} = 0.3 \left(1 + \frac{R_{high}}{R_{low}} \right)$$

$$V_{out} = 100\mu A \cdot R_{set}$$

$$I_{lim} = 150\text{mA} \cdot 1e3 / R_{lim}$$

Vout	Rset	ASTRON nr	Vgood	Rhigh	ASTRON nr
5V0	51K	AST02179	4V8	15K	AST01540
3V3	33K2	AST02177	2V8	8K2	AST01333
2V5	25K5	AST02176	2V3	6K8	AST02163
1V8	18K	AST02178	1V7	4K7	AST01979

ASTRON

DESIGN

Central Power ADC Power

SIZE

A1

Filename

LDO_POWERSUPPLY

REV

3.1

DRAWN BY

Sieds / Gijs

SHEET

62 of 76

DATE

08/04/2022:13:16

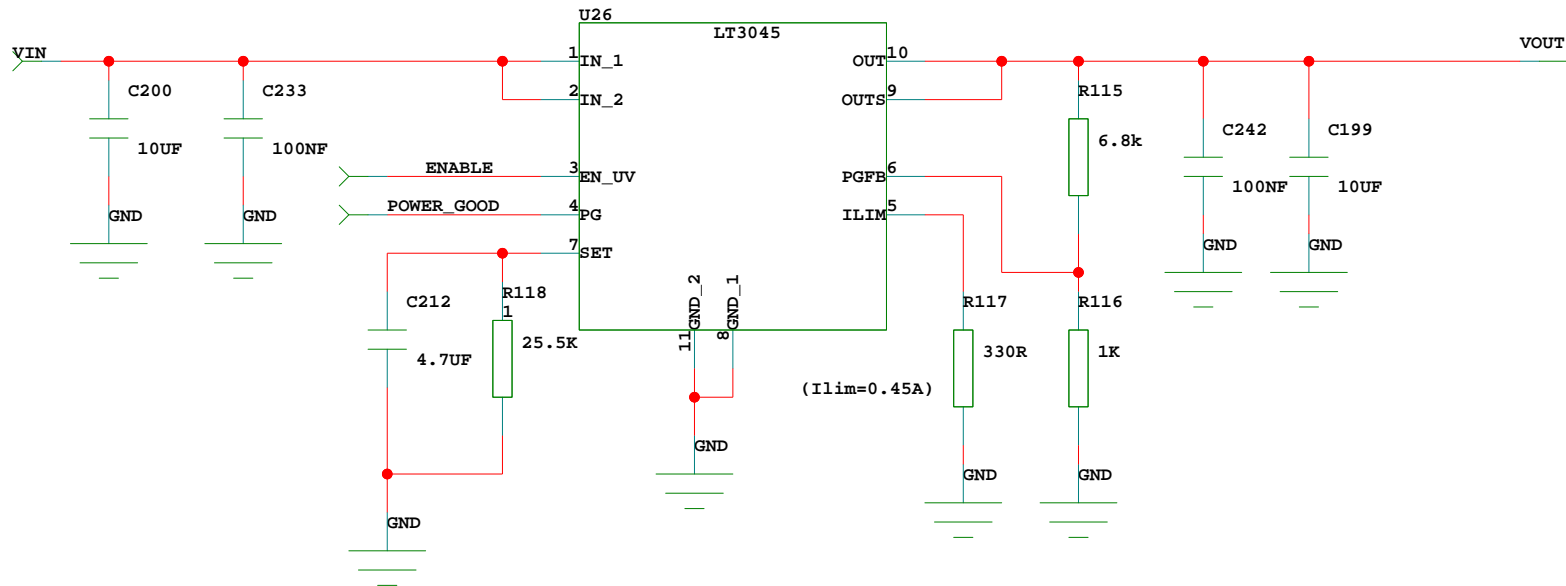

$$V_{good} = 0.3 \left(1 + \frac{R_{high}}{R_{low}} \right)$$

$$V_{out} = 100\mu A \cdot R_{set}$$

$$I_{lim} = 150\text{mA} \cdot 1e3 / R_{lim}$$

Vout	Rset	ASTRON nr	Vgood	Rhigh	ASTRON nr
5V0	51K	AST02179	4V8	15K	AST01540
3V3	33K2	AST02177	2V8	8K2	AST01333
2V5	25K5	AST02176	2V3	6K8	AST02163
1V8	18K	AST02178	1V7	4K7	AST01979

ASTRON

DESIGN

Central Power supply for CLock

SIZE

A1

Filename

LDO_POWERSUPPLY

REV

3.1

DRAWN BY

Sieds / Gijs

SHEET

63 of 76

DATE

08/04/2022:13:16

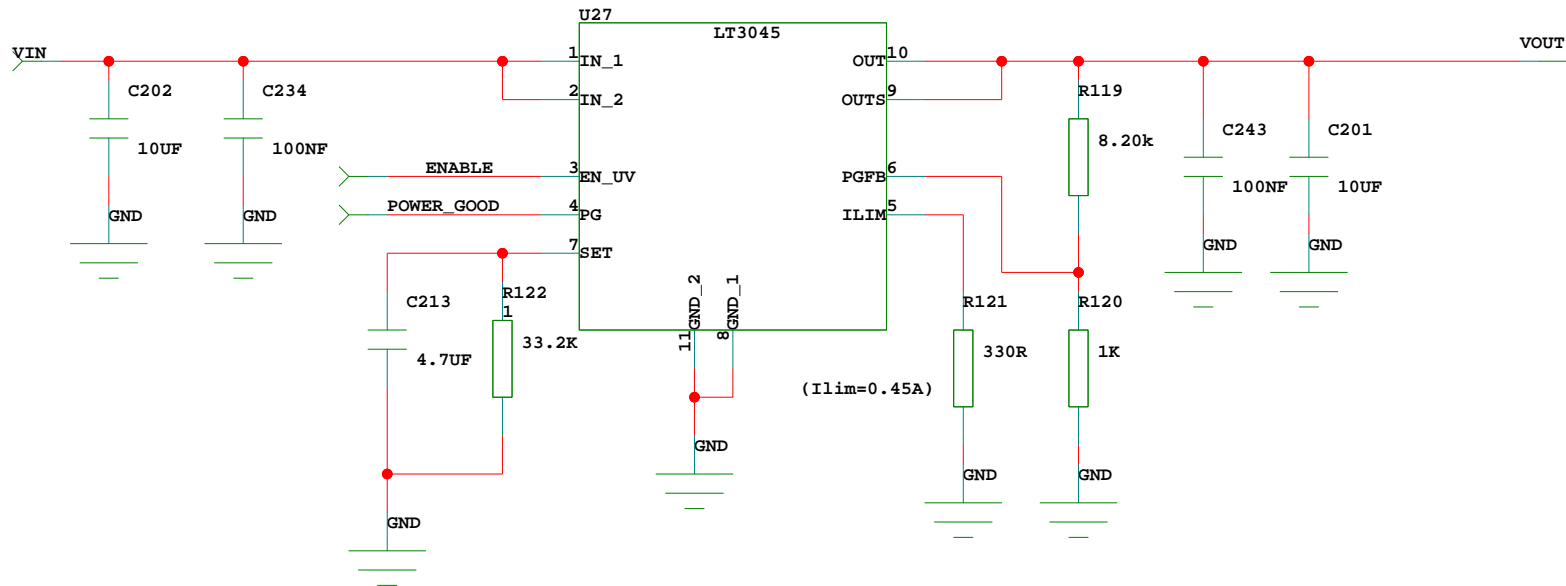

$$V_{good} = 0.3 \left(1 + \frac{R_{high}}{R_{low}} \right)$$

$$V_{out} = 100\mu A \cdot R_{set}$$

$$I_{lim} = 150\text{mA} \cdot 1e3 / R_{lim}$$

Vout	Rset	ASTRON nr	Vgood	Rhigh	ASTRON nr
5V0	51K	AST02179	4V8	15K	AST01540
3V3	33K2	AST02177	2V8	8K2	AST01333
2V5	25K5	AST02176	2V3	6K8	AST02163
1V8	18K	AST02178	1V7	4K7	AST01979

ASTRON

DESIGN

Central Power for Control (3V3)

SIZE

A1

Filename

LDO_POWERSUPPLY

REV

3.1

DRAWN BY

Sieds / Gijs

SHEET

64 of 76

DATE

08/04/2022:13:16

1

2

3

4

5

E

D

C

B

A

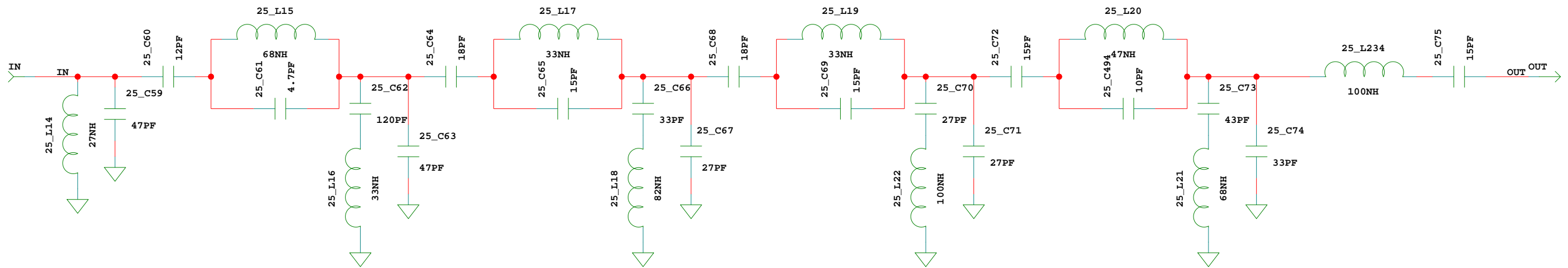

ASTRON

DESIGN			BP 110 - 190 MHz CH0		
SIZE	Filename			REV	
A3		BP_110_190_MHz		3.1	
DRAWN BY Sieds / Gijs		SHEET	65 of 76	DATE	08/04/2022:13:16

1

2

3

4

5

E

D

C

B

A

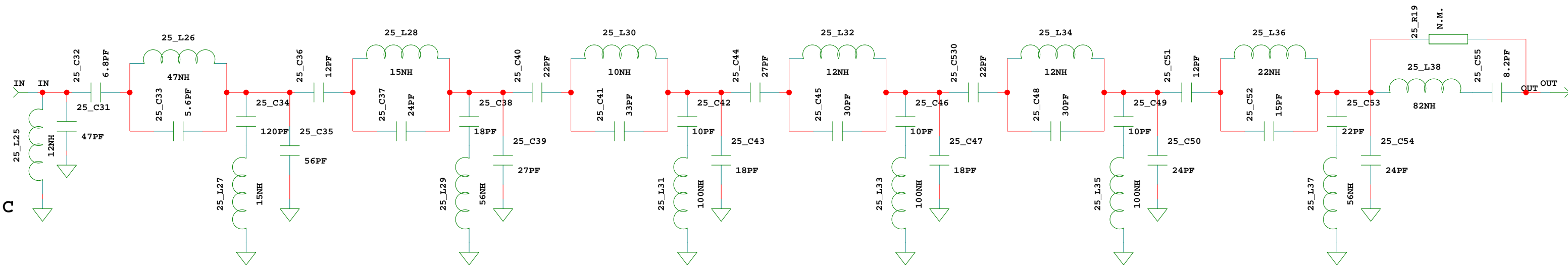

ASTRON

DESIGN			BP 170 - 230 MHz CH0		
SIZE	Filename			REV	
A3		BP_170_230_MHz		3.1	
DRAWN BY Sieds / Gijs		SHEET 66 of 76		DATE 08/04/2022:13:16	

1

2

3

4

5

E

D

C

B

A

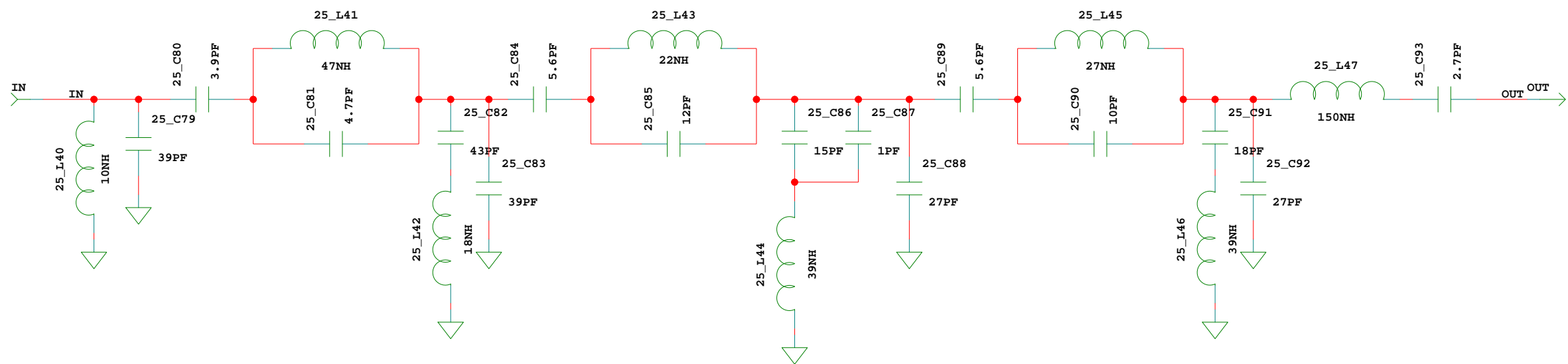

ASTRON

DESIGN			BP 210 - 270 MHz CH0		
SIZE	Filename	REV			
A3		BP210_270_MHz		3.1	
DRAWN BY Sieds / Gijs		SHEET 67 of 76		DATE 08/04/2022:13:16	

1

2

3

4

5

E

D

C

B

A

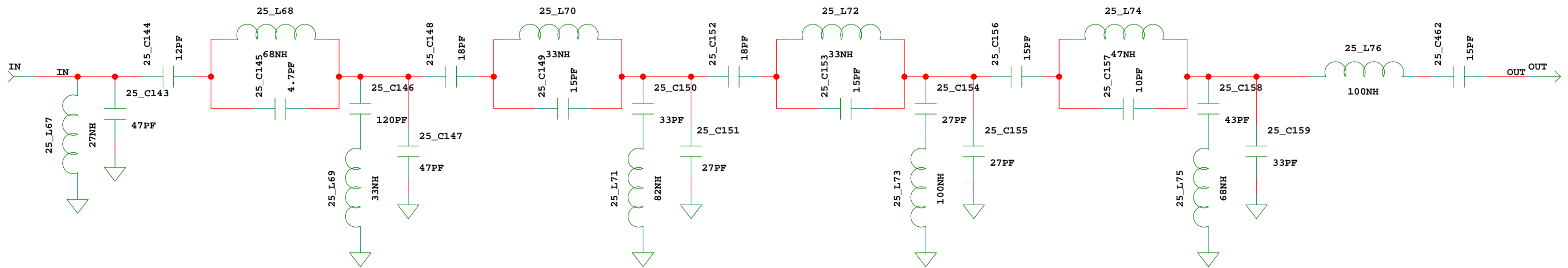

ASTRON

DESIGN			BP 110 - 190 MHz CH1		
SIZE	Filename			REV	
A3		BP_110_190_MHz		3.1	
DRAWN BY Sieds / Gijs		SHEET	68 of 76	DATE	08/04/2022:13:16

1

2

3

4

5

E

D

C

B

A

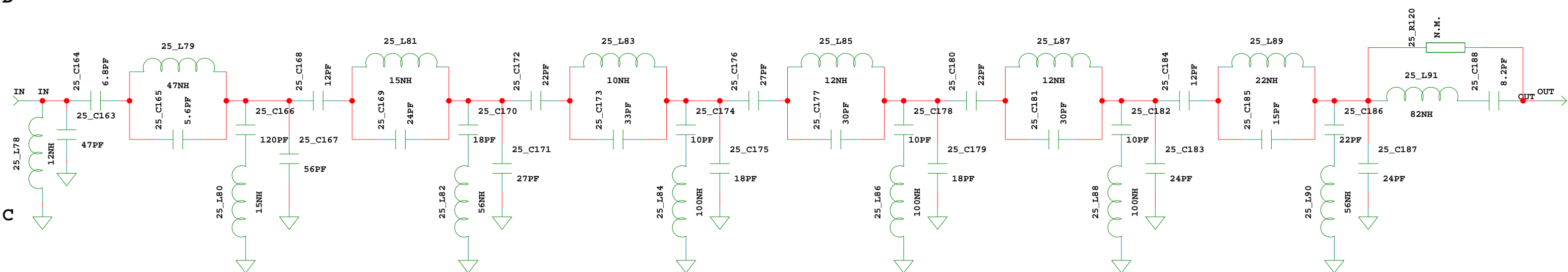

ASTRON

DESIGN			BP 170 - 230 MHz CH1		
SIZE	Filename			REV	
A3		BP_170_230_MHz		3.1	
DRAWN BY Sieds / Gijs		SHEET 69 of 76	DATE 08/04/2022:13:16		

1

2

3

4

5

E

D

C

B

A

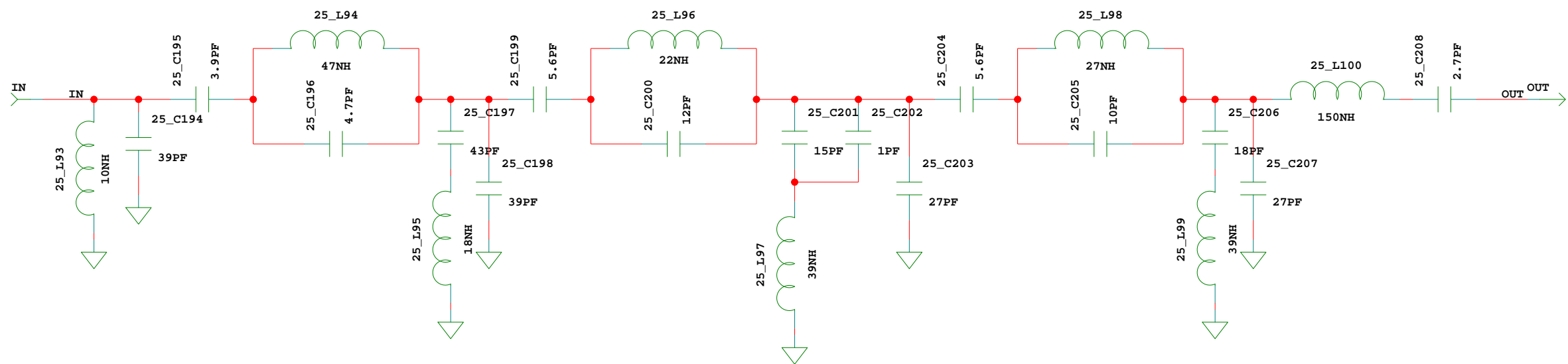

ASTRON

DESIGN		BP 210 - 270 MHz CH1	
SIZE	Filename	REV	
A3	BP210_270_MHz	3.1	
DRAWN BY Sieds / Gijs		SHEET 70 of 76	DATE 08/04/2022:13:16

1

2

3

4

5

E

D

C

B

A

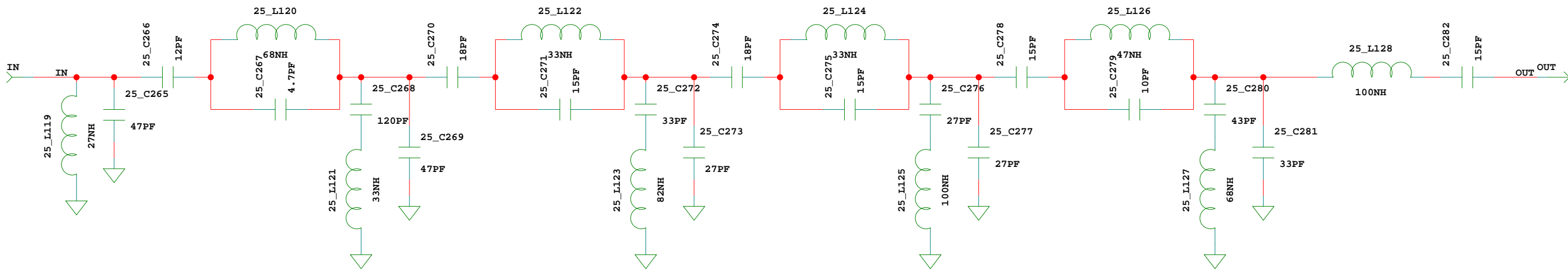

ASTRON

DESIGN			BP 110 - 190 MHz CH2		
SIZE	Filename			REV	
A3		BP_110_190_MHz		3.1	
DRAWN BY Sieds / Gijs		SHEET	71 of 76	DATE	08/04/2022:13:16

1

2

3

4

5

E

D

C

B

A

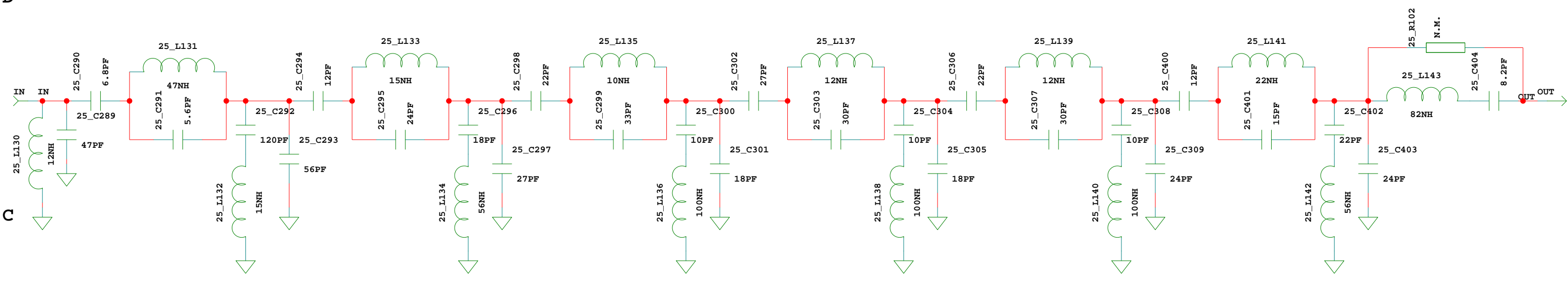

ASTRON

BP 170 - 230 MHz CH2

SIZE	Filename	REV
A3	BP_170_230_MHz	3.1
DRAWN BY	SHEET	DATE
Sieds / Gijs	72 of 76	08/04/2022:13:16

1

2

3

4

5

E

D

C

B

A

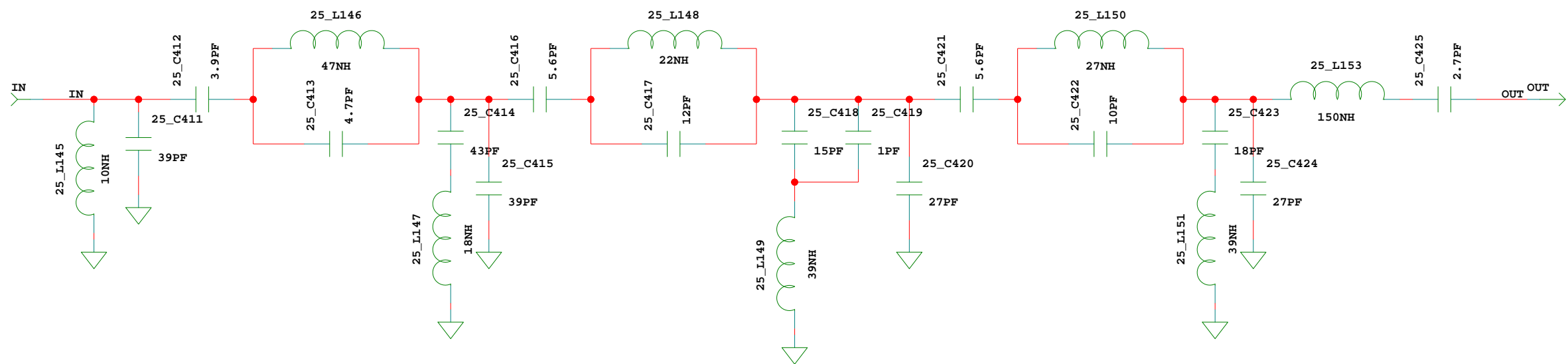

ASTRON

DESIGN			BP 210 - 270 MHz CH2		
SIZE	Filename	REV			
A3		BP210_270_MHz		3.1	
DRAWN BY Sieds / Gijs		SHEET 73 of 76	DATE 08/04/2022:13:16		

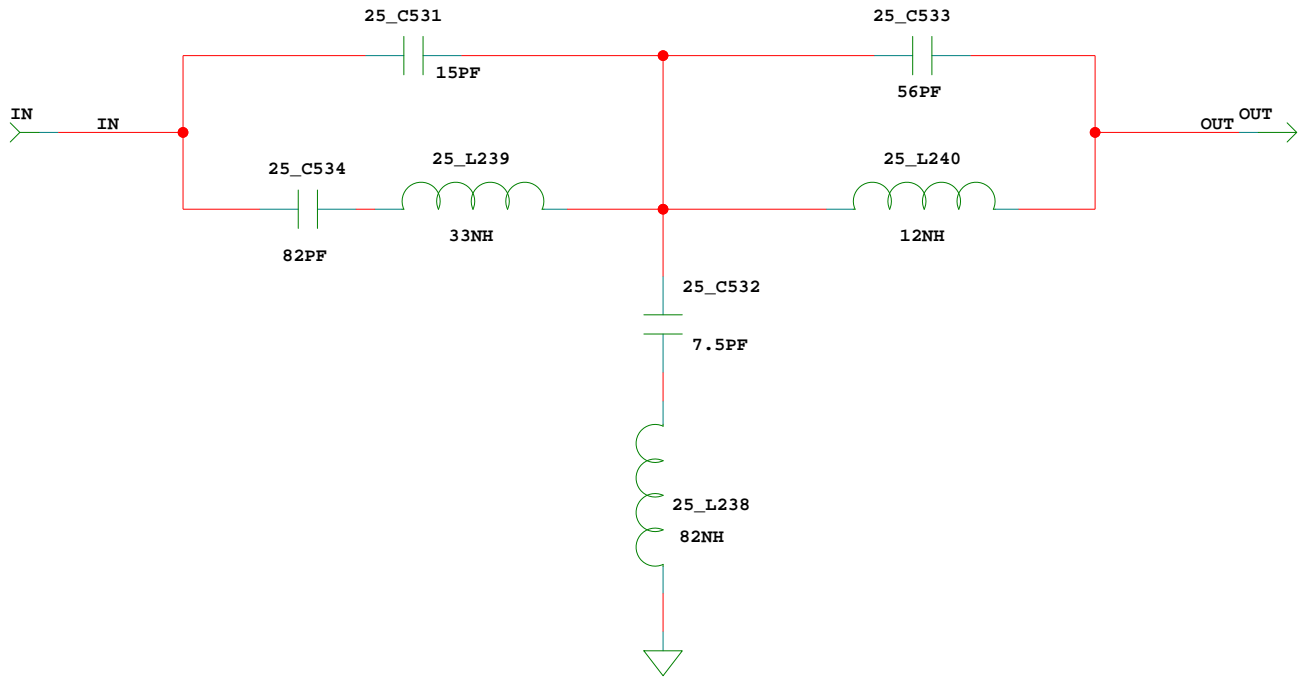

ASTRON / INAF

DESIGN

DAB Filter 174 to 240 MHz

SIZE

A1

Filename

DAB_FILTER

REV

3.1

DRAWN BY

Sieds / Gijs

SHEET

74 of 76

DATE

08/04/2022:13:16

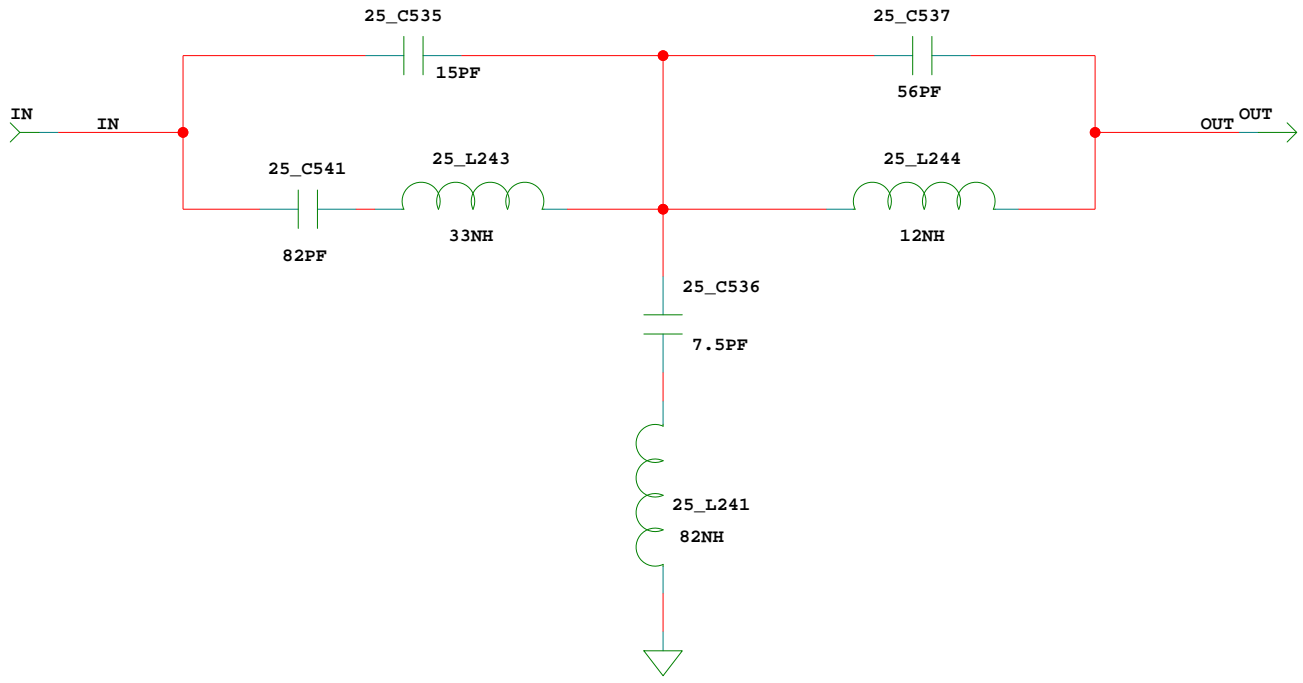

ASTRON / INAF

DESIGN

DAB Filter 174 to 240 MHz

SIZE

A1

Filename

DAB_FILTER

REV

3.1

DRAWN BY

Sieds / Gijs

SHEET

75 of 76

DATE

08/04/2022:13:16

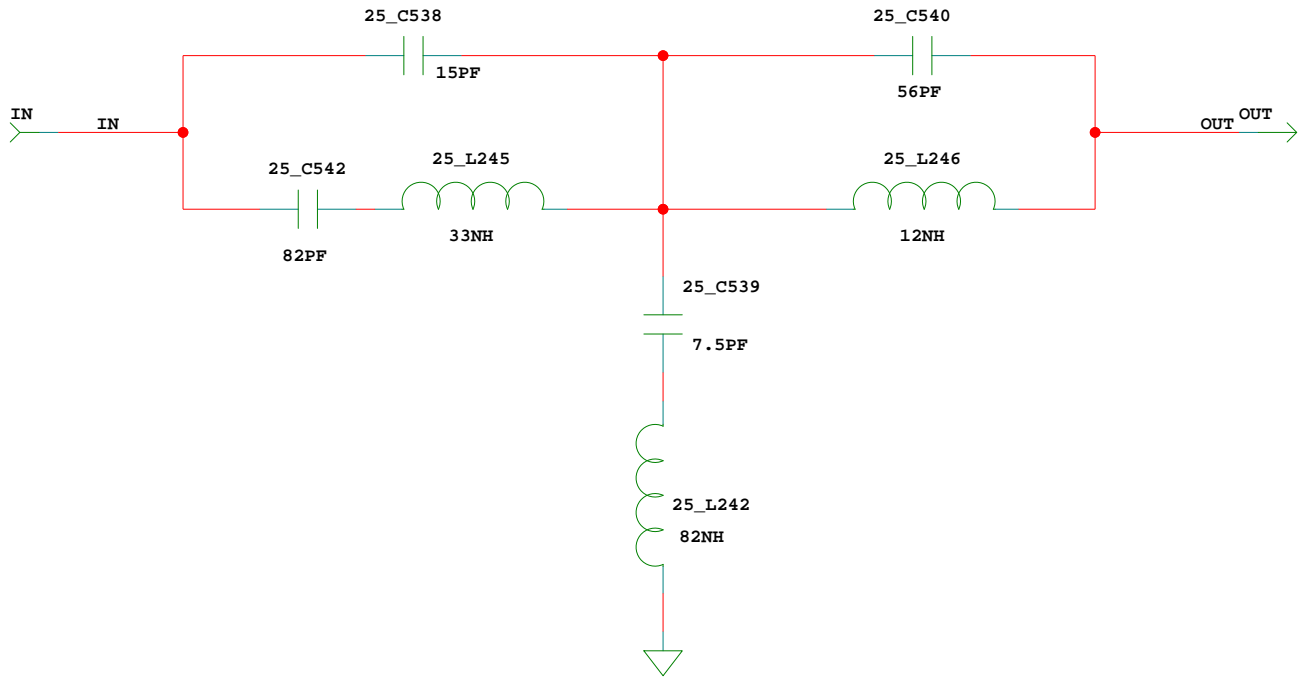

ASTRON / INAF

DESIGN

DAB Filter 174 to 240 MHz

SIZE

A1

Filename

DAB_FILTER

REV

3.1

DRAWN BY

Sieds / Gijs

SHEET

76 of 76

DATE

08/04/2022:13:16